



REPUBLIC OF THE PHILIPPINES  
**NATIONAL POWER CORPORATION**  
(Pambansang Korporasyon sa Elektrisidad)

## **TERMS OF REFERENCE**

**Name of Project :** CONSTRUCTION OF ADDITIONAL BREASTING  
STRUCTURES FOR POWER BARGE 120 AT  
MOGPOG, MARINDUQUE

**Project Location :** BALANACAN PORT, MOGPOG, MARINDUQUE

**Specs No :** LuzP21Z1352Sc

### **Contents:**

- |                    |  |
|--------------------|--|
| <b>Section I</b>   | - <b>Instructions to Bidders</b>   |
| <b>Section II</b>  | - <b>General Conditions of Contract</b>  |
| <b>Section III</b> | - <b>Technical Specifications</b> <ul style="list-style-type: none"><li>• <b>Project Highlights</b></li><li>• <b>Civil Works</b></li></ul> |
| <b>Section IV</b>  | - <b>Bill of Quantities</b>  |
| <b>Section V</b>   | - <b>Bidding Forms</b>   |
| <b>Section VI</b>  | - <b>Bid Drawings</b>  |

Design and Development Department



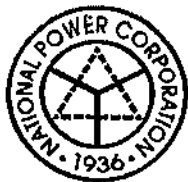

# National Power Corporation

## NEGOTIATED PROCUREMENT

### NP 2022-0017

- The NATIONAL POWER CORPORATION (NPC), through its approved Corporate Budget of CY 2022 intends to apply the sum of **(Please see schedule below)** being the Approved Budget for the Contract (ABC) to payments under the contract. Bids received in excess of the ABC shall be automatically rejected at Bid opening.

PR Nos./PB Ref No. & Description	Similar Contracts	Pre-Nego Conference	Bid Submission / Opening	ABC
HO-PIB22-002 / PB220323-AD00038 (NP)  Construction of Additional Breasting Structures for Power Barge 120 at Mogpog, Marinduque  • PCAB License: License Category of at least <b>"Category D – General Engineering"</b> and registration classification of at least <b>"Small B – Port, Harbor or Offshore Engineering"</b>	Construction / Rehabilitation of Mooring Facilities, piers, port terminal or loading/unloading jetty	21 November 2022 9:30 A.M	05 December 2022 9:30 A.M	₱ 6,559,000.00
<b>Venue: Kañao Function Room, NPC Bldg. Diliman, Quezon City</b>				

- The NPC now invites Bids for Items listed above. Delivery of the items is required within **(see table below)** in the Technical Specifications in the Terms of Reference. Bidders should have completed from the date of submission and receipt of bids, a contract similar to the Project., must be at least equivalent to an amount as stated in the Terms of Reference.

PR Nos./PB Ref Nos.	Delivery Period / Contract Duration	Relevant Period of SLCC reckoned from the date of submission & receipt of bids
HO-PIB22-002	Forty Five (45) Calendar Days	-

- Bidding will be conducted through Negotiated Procurement procedures using a non-discretionary "pass/fail" criterion as specified in the Implementing Rules and Regulations (IRR) of Republic Act (RA) 9184, otherwise known as the "Government Procurement Reform Act".
- Interested bidders may obtain further information from BAC Secretariat at the address given below during office hours.
- A complete set of TOR will be provided to the interested Bidders from the address below. It may also be downloaded from the websites of the Philippine Government Electronic Procurement System (PhilGEPS) <http://www.philgeps.gov.ph> and National Power Corporation <http://www.napocor.gov.ph>.
- NPC will hold a Pre-Negotiation Conference on the date, time and venue stated above.

Only registered bidder/s shall be allowed to participate for the conduct of virtual pre-bid conference. **Unregistered bidders** may attend the Pre-Bid Conference at the Kañao Room, NPC subject to the following:

- a. Only a maximum of two (2) representatives from each bidder / company shall be allowed to participate
  - b. A "No Face mask / No Entry" policy shall be implemented in the NPC premises. Face mask shall be 3-ply surgical or KN95 mask type.
  - c. The requirements herein stated including the medium of submission shall be subject to GPPB Resolution No. 09-2020 dated 07 May 2020
  - d. The Guidelines on the Implementation of Early Procurement Activities (EPA) shall be subject to GPPB Circular No. 06-2019 dated 17 July 2019
7. Bids must be delivered to the address below on the date stated above. Late bids shall not be accepted.
  8. NPC reserves the right to accept or reject any bid, to annul the bidding process, and to reject all bids at any time prior to contract award, without thereby incurring any liability to the affected bidder or bidders.
  9. For further information, please refer to:

**Bids and Contracts Services Division,  
Logistics Department**  
BIR Road cor. Quezon Avenue  
Diliman, Quezon City  
Tel Nos.: 8924-5211 and  
8921-3541 local 5564  
Fax No.: 8922-1622  
Email: [bcsd@napocor.gov.ph](mailto:bcsd@napocor.gov.ph)

  
**RENE B. BARRUELA**  
Vice President, Corporate Affairs Group and  
Chairman, Bids and Awards Committee

# SECTION I

# INSTRUCTION TO BIDDERS

**SECTION I - INSTRUCTIONS TO BIDDERS****TABLE OF CONTENTS**

CLAUSE NO.	TITLE	PAGE NO.
<b>A. GENERAL</b>		<b>1</b>
1.	Scope of Bid	1
2.	Source of Funds	1
3.	Corrupt, Fraudulent, Collusive, Coercive, and Obstructive Practices	1
4.	Conflict of Interest	3
5.	Eligible Bidders	4
6.	Bidder's Responsibilities	5
7.	Origin of Goods and Services	8
8.	Subcontracts	8
9.	Negotiation	8
10.	Clarification and Amendment of Bidding Documents	8
<b>B. PREPARATION OF BIDS</b>		<b>9</b>
11.	Language of Bids	9
12.	Documents Comprising the Bid: Eligibility and Technical Components	9
13.	Documents Comprising the Bid: Financial Component	13
14.	Alternative Bids	14
15.	Bid Prices	14
16.	Bid Currencies	15
17.	Bid Validity	15
18.	Format and Signing of Bids	15
19.	Sealing and Marking of Bids	15
<b>C. SUBMISSION AND OPENING OF BIDS</b>		<b>16</b>
20.	Deadline for Submission of Bids	16
21.	Opening and Preliminary Examination of Bids	16
<b>D. EVALUATION AND COMPARISON OF BIDS</b>		<b>17</b>
22.	Process to be Confidential	17
23.	Clarification of Bids	18
24.	Detailed Evaluation and Comparison of Bids	18
25.	Post Qualification	19
26.	Reservation Clause	22
<b>E. AWARD OF CONTRACT</b>		<b>23</b>
27.	Contract Award	23
28.	Signing of the Contract	23
29.	Performance Security	24
30.	Notice to Proceed	26
31.	Protest Mechanism	26

## SECTION I - INSTRUCTIONS TO BIDDERS

### A. General

#### 1. Scope of Bid

1.1. The National Power Corporation (NPC), with office address stated below, wishes to conduct the negotiated procurement for the **CONSTRUCTION OF ADDITIONAL BREASTING STRUCTURES FOR POWER BARGE 120 AT MOGPOG, MARINDUQUE (LuzP21Z1352Sc)** as described in Section III – Technical Specifications, to selected Bidders in accordance with the revised IRR of R.A. 9184.

1.2. NPC's address is:

Office : **Bids and Contracts Services Division (BCSD)  
Logistics Department**  
Address : Ground Floor, Building No. 1  
National Power Corporation  
BIR Road corner Quezon Avenue  
Diliman, Quezon City, Metro Manila 1100  
Tel Nos. : 8924-5211 and 8921-3541 Loc. 5564  
Tel/Fax No. : 8922-1622  
Email : [bcsd@napocor.gov.ph](mailto:bcsd@napocor.gov.ph)  
Website : [www.napocor.gov.ph](http://www.napocor.gov.ph)

1.3. Contract scope shall be as specified in the Technical Specifications and Bill of Quantities. All appurtenances and associated supplies/works required to complete the works shall be deemed included in the scope of the contract. The successful bidder will be expected to complete the Works within the contract duration specified in the Technical Specifications, reckoned from the contract effectivity date.

1.4. Partial bid is not allowed. The infrastructure project is packaged in a single lot and the lot shall not be divided into sub-lots for the purpose of bidding, evaluation, and contract award.

#### 2. Source of Funds

2.1 The Government of the Philippines (GOP) through the corporate funds of NPC for CY 2022 in the amount of **SIX MILLION FIVE HUNDRED FIFTY NINE THOUSAND PESOS (P 6,559,000.00)** shall be used to finance the cost of this procurement.

2.2 Payments will be made by NPC upon approval of the claims in accordance with the provisions, terms and conditions of the contract and existing and applicable law.

#### 3. Corrupt, Fraudulent, Collusive, Coercive, and Obstructive Practices

3.1. NPC, as well as bidders and contractors, shall observe the highest standard of ethics during the procurement and execution of the contract. In pursuance of this policy, NPC:

(a) defines, for purposes of this provision, the terms set forth below as follows:

- (i) "corrupt practice" means behavior on the part of officials in the public or private sectors by which they improperly and unlawfully enrich themselves, others, or induce others to do so, by misusing the position in which they are placed, and includes the offering, giving, receiving, or soliciting of anything of value to influence the action of any such official in the procurement process or in contract execution; entering, on behalf of NPC, into any contract or transaction manifestly and grossly disadvantageous to the same, whether or not the public officer profited or will profit thereby, and similar acts as provided in Republic Act 3019;
- (ii) "fraudulent practice" means a misrepresentation of facts in order to influence a procurement process or the execution of a contract to the detriment of NPC, and includes collusive practices among Bidders (prior to or after Bid submission) designed to establish bid prices at artificial, non-competitive levels and to deprive NPC of the benefits of free and open competition;
- (iii) "collusive practices" means a scheme or arrangement between two or more Bidders, with or without the knowledge of NPC, designed to establish bid prices at artificial, non-competitive levels; and
- (iv) "coercive practices" means harming or threatening to harm, directly or indirectly, persons, or their property to influence their participation in a procurement process, or affect the execution of a contract;
- (v) "obstructive practice" is
  - (aa) deliberately destroying, falsifying, altering or concealing of evidence material to an administrative proceedings or investigation or making false statements to investigators in order to materially impede an administrative proceedings or investigation of NPC or any foreign government/foreign or international financing institution into allegations of a corrupt, fraudulent, coercive or collusive practice; and/or threatening, harassing or intimidating any party to prevent it from disclosing its knowledge of matters relevant to the administrative proceedings or investigation or from pursuing such proceedings or investigation; or
  - (bb) acts intended to materially impede the exercise of the inspection and audit rights of NPC or any foreign government/foreign or international financing institution herein.

- (b) will reject a proposal for award if it determines that the Bidder recommended for award has engaged in corrupt or fraudulent practices in competing for the Contract; and
  - (c) will declare a firm ineligible, either indefinitely or for a stated period of time, to be awarded Contract funded by the Funding Source if it at any time determines that the firm has engaged in corrupt or fraudulent practices in competing or, or in executing, a Contract funded by the Funding Source.
- 3.2. Further, NPC will seek to impose the maximum civil, administrative, and/or criminal penalties available under the applicable laws on individuals and organizations deemed to be involved in any of the practices mentioned in **ITB Clause 3.1(a)**.
- 3.3. Furthermore, NPC reserve the right to inspect and audit records and accounts of a contractor in the bidding for and performance of a contract themselves or through independent auditors as reflected in the **GCC Clause 32**.
- 4. Conflict of Interest**
- 4.1. All Bidders found to have conflicting interests shall be disqualified to participate in the procurement at hand, without prejudice to the imposition of appropriate administrative, civil, and criminal sanctions. A Bidder may be considered to have conflicting interests with another Bidder in any of the events described in paragraphs (a) through (c) and a general conflict of interest in any of the circumstances set out in paragraphs (d) through (g) below:
- (a) A Bidder has controlling shareholders in common with another Bidder;
  - (b) A Bidder receives or has received any direct or indirect subsidy from any other Bidder;
  - (c) A Bidder has the same legal representative as that of another Bidder for purposes of this Bid;
  - (d) A Bidder has a relationship, directly or through third parties, that puts them in a position to have access to information about or influence on the bid of another Bidder or influence the decisions of NPC regarding this bidding process;
  - (e) A Bidder submits more than one bid in this bidding process. However, this does not limit the participation of subcontractors in more than one bid;
  - (f) A Bidder who participated as a consultant in the preparation of the design or technical specifications of the goods and related services that are the subject of the bid; or
  - (g) A Bidder who lends, or temporarily seconds, its personnel to firms or organizations which are engaged in consulting services for the preparation related to procurement for or implementation of the project, if the personnel would be involved in any capacity on the same project.



- 4.2. In accordance with Section 47 of the IRR of RA 9184, all Bidding Documents shall be accompanied by a sworn affidavit of the Bidder that it is not related to the Head of NPC, members of the Bids and Awards Committee (BAC), members of the Technical Working Group (TWG), members of the BAC Secretariat, the head of the Project Management Office (PMO) or the end-user unit, and the project consultants, by consanguinity or affinity up to the third civil degree. On the part of the Bidder, this Clause shall apply to the following persons:
- (a) If the Bidder is an individual or a sole proprietorship, to the Bidder himself;
  - (b) If the Bidder is a partnership, to all its officers and members;
  - (c) If the Bidder is a corporation, to all its officers, directors, and controlling stockholders;
  - (d) If the Bidder is a cooperative, to all its officers, directors, and controlling shareholders or members; and
  - (e) If the Bidder is a joint venture (JV), the provisions of items (a), (b), (c) or (d) of this Clause shall correspondingly apply to each of the members of the said JV, as may be appropriate.

Relationship of the nature described above or failure to comply with this Clause will result in the automatic disqualification of a Bidder.

## 5. Eligible Bidders

- 5.1. The following persons shall be eligible to participate in this Bidding:
- (a) Duly licensed Filipino citizens/sole proprietorships;
  - (b) Partnerships duly organized under the laws of the Philippines and of which at least Sixty Percent (60%) of the interest belongs to citizens of the Philippines;
  - (c) Corporations duly organized under the laws of the Philippines, and of which at least Sixty Percent (60%) of the outstanding capital stock belongs to citizens of the Philippines;
  - (d) Cooperatives duly organized under the laws of the Philippines.
  - (e) Persons/entities forming themselves into a JV, i.e., a group of two (2) or more persons/entities that intend to be jointly and severally responsible or liable for a particular contract: *Provided, however*, that, in accordance with Executive Order No. 65 (EO 65) s. 2018, Filipino ownership or interest of the joint venture concerned shall be at least Sixty Percent (60%): *Provided, further*, that joint ventures in which Filipino ownership or interest is less than Sixty Percent (60%) may be eligible where the structures to be built require the application of techniques and/or technologies which are not adequately possessed by a person/entity meeting the Sixty Percent (60%) Filipino ownership requirement: *Provided, finally*, that in the latter case, Filipino ownership or interest shall not be less than twenty five percent (25%). For this purpose, Filipino ownership or interest shall be based on the

contributions of each of the members of the joint venture as specified in their JVA.

- 5.2. Government owned or controlled corporations (GOCCs) may be eligible to participate only if they can establish that they (a) are legally and financially autonomous, (b) operate under commercial law, and (c) are not attached agencies of NPC.
- 5.3. The prospective bidder must have completed a Single Largest Completed Contract (SLCC) that is similar to the contract to be bid, and whose value, adjusted to current prices using the Philippine Statistics Authority (PSA) consumer price indices, must be at least fifty percent (50%) of the ABC to be bid: *Provided, however,* That contractors under Small A and Small B categories without similar experience on the contract to be bid may be allowed to bid if the cost of such contract is not more than the Allowable Range of Contract Cost (ARCC) of their registration based on the guidelines as prescribed by the PCAB.

For this purpose, similar contracts shall refer to contracts and/or projects involving construction/rehabilitation of mooring facilities, piers, port terminal or loading/unloading jetty.

The Single Largest Completed Contract (SLCC) as declared by the bidder shall be verified and validated to ascertain such completed contract. Hence, bidders must ensure access to sites of such projects/equipment to NPC representatives for verification and validation purposes during post-qualification process.

It shall be a ground for disqualification, if verification and validation cannot be conducted for reasons attributable to the Bidder.

- 5.4. The Bidder must submit a computation of its Net Financial Contracting Capacity (NFCC), which must be at least equal to the ABC to be bid, calculated as follows:

$$\text{NFCC} = [(\text{Current assets minus current liabilities}) (15)] \text{ minus the value of all outstanding or uncompleted portions of the projects under ongoing contracts, including awarded contracts yet to be started coinciding with the contract for this Project.}$$

The values of the domestic bidder's current assets and current liabilities shall be based on the latest Audited Financial Statements (AFS) submitted to the BIR.

For purposes of computing the foreign bidders' NFCC, the value of the current assets and current liabilities shall be based on their audited financial statements prepared in accordance with international financial reporting standards.

## 6. Bidder's Responsibilities

- 6.1. The Bidder or its duly authorized representative shall submit an Omnibus sworn statement in the form prescribed in **Section V – Bidding Forms** as required in ITB Clause 12.1(b)(ii).
- 6.2. The Bidder is responsible for the following:

- (a) Having taken steps to carefully examine all of the Bidding Documents;
- (b) Having acknowledged all conditions, local or otherwise, affecting the implementation of the contract;
- (c) Having made an estimate of the facilities available and needed for the contract to be bid, if any;
- (d) Having complied with its responsibility to inquire or secure Supplemental/Bid Bulletin/s as provided under ITB Clause 10.3.
- (e) Ensuring that it is not "blacklisted" or barred from bidding by the GoP or any of its agencies, offices, corporations, or LGUs, including foreign government/foreign or international financing institution whose blacklisting rules have been recognized by the GPPB;
- (f) Ensuring that each of the documents submitted in satisfaction of the bidding requirements is an authentic copy of the original, complete, and all statements and information provided therein are true and correct;
- (g) Authorizing the Head of the NPC or its duly authorized representative/s to verify all the documents submitted;
- (h) Ensuring that the signatory is the duly authorized representative of the Bidder, and granted full power and authority to do, execute and perform any and all acts necessary to participate, submit the bid, and to sign and execute the ensuing contract, accompanied by the duly notarized Special Power of Attorney, Board/Partnership Resolution, or Secretary's Certificate, whichever is applicable;
- (i) Complying with the disclosure provision under Section 47 of RA 9184 and its IRR in relation to other provisions of RA 3019;
- (j) Complying with existing labor laws and standards, in the case of procurement of services. Moreover, bidder undertakes to:
  - (i) Ensure the entitlement of workers to wages, hours of work, safety and health and other prevailing conditions of work as established by national laws, rules and regulations; or collective bargaining agreement; or arbitration award, if and when applicable.  
  
In case there is a finding by NPC or the DOLE of underpayment or non-payment of workers' wage and wage-related benefits, bidder agrees that the performance security or portion of the contract amount shall be withheld in favor of the complaining workers pursuant to appropriate provisions of Republic Act No. 9184 without prejudice to the institution of appropriate actions under the Labor Code, as amended, and other social legislations.
  - (ii) Comply with occupational safety and health standards and to correct deficiencies, if any.

In case of imminent danger, injury or death of the worker, bidder undertakes to suspend contract implementation pending clearance to proceed from the DOLE Regional Office and to comply with Work Stoppage Order; and

- (iii) Inform the workers of their conditions of work, labor clauses under the contract specifying wages, hours of work and other benefits under prevailing national laws, rules and regulations; or collective bargaining agreement; or arbitration award, if and when applicable, through posting in two (2) conspicuous places in the establishment's premises; and
- (k) Ensuring that it did not give or pay, directly or indirectly, any commission, amount, fee, or any form of consideration, pecuniary or otherwise, to any person or official, personnel or representative of the;

Failure to observe any of the above responsibilities shall be at the risk of the Bidder concerned.

- 6.3. The Bidder, by the act of submitting its bid, shall be deemed to have inspected the site, determined the general characteristics of the contract works and the conditions for this Project and examine all instructions, forms, terms, and project requirements in the Bidding Documents.
- 6.4. It shall be the sole responsibility of the prospective bidder to determine and to satisfy itself by such means as it considers necessary or desirable as to all matters pertaining to this Project, including: (a) the location and the nature of the contract, project, or work; (b) climatic conditions; (c) transportation facilities; (c) nature and condition of the terrain, geological conditions at the site communication facilities, requirements, location and availability of construction aggregates and other materials, labor, water, electric power and access roads; and (d) other factors that may affect the cost, duration and execution or implementation of the contract, project, or work.
- 6.5. NPC shall not assume any responsibility regarding erroneous interpretations or conclusions by the prospective or eligible bidder out of the data furnished by NPC. However, NPC shall ensure that all information in the Bidding Documents, including supplemental/bid bulletins issued are correct and consistent.
- 6.6. Before submitting their bids, the Bidders are deemed to have become familiar with all existing laws, decrees, ordinances, acts and regulations of the Philippines which may affect the contract in any way.
- 6.7. The Bidder shall bear all costs associated with the preparation and submission of his bid, and NPC will in no case be responsible or liable for those costs, regardless of the conduct or outcome of the bidding process.
- 6.8. The Bidder should note that NPC will accept bids only from those that have paid the applicable fee for the Bidding Documents at the office indicated in the Invitation to Bid.

## 7. Origin of Goods and Services

There is no restriction on the origin of Goods, or Contracting of Works or Services other than those prohibited by a decision of the United Nations Security Council taken under Chapter VII of the Charter of the United Nations.

## 8. Subcontracts

- 8.1. Only a maximum of fifty percent (50%) of the Works may be subcontracted. All Subcontractors must be approved by NPC. Subcontracting of any portion shall not relieve the Bidder from any liability or obligation that may arise from the contract for this Project.
- 8.2. Subcontractors must submit the documentary requirements under **ITB** Clause 12 and comply with the eligibility criteria. In the event that any subcontractor is found by NPC to be ineligible, the subcontracting of such portion of the Works shall be disallowed.
- 8.3. The Bidder may identify the subcontractor to whom a portion of the Works will be subcontracted at any stage of the bidding process or during contract implementation. If the Bidder opts to disclose the name of the subcontractor during bid submission, the Bidder shall include the required documents as part of the technical component of its bid.

## 9. Negotiation

- 9.1. Negotiation shall be held at the venue and on the date indicated in the invitation, to clarify concerns on the technical and financial components of this procurement.
- 9.2. Bidders are encouraged to attend the negotiation to ensure that they fully understand NPC's requirements. Non-attendance of the Bidder will in no way prejudice its bid; however, the Bidder is expected to know the changes and/or amendments to the TOR discussed during the negotiation.
- 9.3. Any statement made at the negotiation shall not modify the Terms of Reference unless such statement is specifically identified in writing as an amendment thereto and issued as a Supplemental/Bid Bulletin.
- 9.4. Following completion of the negotiations, NPC shall request all Bidders remaining in the proceedings to submit, on a specified date, a best and final offer with respect to all aspects of their bid proposals.

## 10. Clarification and Amendment of Bidding Documents

- 10.1. Bidders may request for clarifications on any part of the documents for an interpretation during the negotiation meeting.

For such purpose, the BAC may send its official letters/correspondences/notices through email. Upon securing the bidding documents, Bidders shall be required to indicate their official email and alternate email addresses. All letters/correspondences/notices sent by the BAC through the designated/official email shall be considered officially received by all bidders on the date indicated in National Power Corporation's sent folder.

- 10.2. Supplemental/Bid Bulletins may also be issued upon NPC's initiative for purposes of clarifying or modifying any provision of the Bidding Documents not later than seven (7) calendar days before the deadline for the submission and receipt of Bids. Any modification to the Bidding Documents shall be identified as an amendment.
- 10.3. Any Supplemental/Bid Bulletin issued by the BAC shall also be posted in the PhilGEPS and the website of NPC, if available, and at any conspicuous place in the premises of NPC. It shall be the responsibility of all Bidders who have properly secured the Bidding Documents to inquire and secure Supplemental/Bid Bulletins that may be issued by the BAC. However, Bidders who have submitted bids before the issuance of the Supplemental/Bid Bulletin must be informed and allowed to modify or withdraw their bids.

### **B. Preparation of Bids**

#### **11. Language of Bids**

The eligibility requirements or statements, the bids, and all other documents to be submitted to the BAC must be in English. If the eligibility requirements or statements, the bids, and all other documents submitted to the BAC are in foreign language other than English, it must be accompanied by a translation of the documents in English. The documents shall be translated by the relevant foreign government agency, the foreign government agency authorized to translate documents, or a registered translator in the foreign bidder's country; and shall be authenticated by the appropriate Philippine foreign service establishment/post or the equivalent office having jurisdiction over the foreign bidder's affairs in the Philippines. The English translation shall govern, for purposes of interpretation of the bid.

#### **12. Documents Comprising the Bid: Eligibility and Technical Components**

12.1. The first envelope shall contain the following eligibility and technical documents:

(a) Eligibility Documents –

Class "A" Documents

- (i) (a) PhilGEPS Certificate of Registration and Membership under Platinum Category in accordance with Section 8.5.2 of the IRR;

**OR:**

- (b) The following updated and valid Class "A" eligibility documents enumerated under "Annex A" of the Platinum Membership:

1. Registration Certificate from the Securities and Exchange Commission (SEC) for corporations, Department of Trade and Industry (DTI) for sole proprietorship, or Cooperative Development Authority (CDA) for cooperatives;
2. Mayor's/Business permit issued by the city or municipality where the principal place of business of the prospective bidder is located, or the equivalent document for Exclusive Economic Zones or Areas;

In cases of recently expired Mayor's/Business permits, it shall be accepted together with the official receipt as proof that the bidder has applied for renewal within the period prescribed by the concerned local government unit, provided that the renewed permit shall be submitted as a post qualification requirement in accordance with Section 34.2 of the Revised IRR of RA 9184;

3. The prospective bidder's audited financial statements, showing, among others, the prospective bidder's total and current assets and liabilities, stamped "received" by the BIR or its duly accredited and authorized institutions, for the preceding calendar year which should not be earlier than two (2) years from the date of bid submission;
4. Tax clearance per Executive Order 398, Series of 2005, as finally reviewed and approved by the BIR;
5. Valid Philippine Contractors Accreditation Board (PCAB) license and registration for the type and cost of the contract for this Project or Special PCAB License in case of Joint Ventures.

**OR:**

- (c) A combination thereof (i.a and i.b)

In case the bidder opted to submit their Class "A" eligibility documents, the Certificate of PhilGEPS Registration (Platinum Membership) shall remain as a post-qualification requirement to be submitted in accordance with Section 34.2 of the 2016 Revised IRR of RA 9184 (GPPB Circular 07-2017);

- (ii) Statement of all its ongoing government and private contracts, including contracts awarded but not yet started, if any, whether similar or not similar in nature and complexity to the contract to be bid; and

Statement of the Bidder's SLCC similar to the contract to be bid, in accordance with ITB Clause 5.4.

The two statements required shall indicate for each contract the following:

- (ii.1) name of the contract;
- (ii.2) date of the contract;
- (ii.3) contract duration;
- (ii.4) owner's name and address;
- (ii.5) nature of work;

- (ii.6) contractor's role (whether sole contractor, subcontractor, or partner in a JV) and percentage of participation;
- (ii.7) total contract value at award;
- (ii.8) date of completion or estimated completion time;
- (ii.9) total contract value at completion, if applicable;
- (ii.10) percentages of planned and actual accomplishments, if applicable; and
- (ii.11) value of outstanding works, if applicable.

The list of on-going contracts (Form No. NPCSF-INFR-02) shall be supported by the following documents for each on-going contract to be submitted during Post-Qualification:

1. Contract/Purchase Order and/or Notice of Award
2. Certification coming from the project owner/client that the performance is satisfactory as of the bidding date.

The bidder shall declare in this form all his on-going government and private contracts including contracts where the bidder (either as individual or as a Joint Venture) is a partner in a Joint Venture agreement other than his current joint venture where he is a partner. Non declaration will be a ground for disqualification of bid.

Further, the Statement of the bidder's Single Largest Completed Contract (SLCC) similar to the contract to be bid (Form No. NPCSF-INFR-03) shall be supported by the following documents to be submitted during Bid Opening:

1. Contract/Purchase Order
  2. Owner's Certificate of Final Acceptance issued by the project owner other than the contractor or a final rating of at least Satisfactory in the Constructors Performance Evaluation System (CPES). In case of contracts with the private sector, an equivalent document (Ex. Official Receipt or Sales Invoice) shall be submitted.
- (iii) Valid Philippine Contractors Accreditation Board (PCAB) license or Special PCAB License in case of Joint Ventures, and registration for the type and cost of the contract for this Project as follows:
- The required License issued by the Philippine Contractors Accreditation Board (PCAB): License Category of at least **"CATEGORY D – GENERAL ENGINEERING"** and registration classification of at least **"SMALL B – PORT, HARBOR OR OFFSHORE ENGINEERING"**
- (iv) NFCC computation in accordance with ITB Clause 5.5.



Class "B" Documents

- (v) If applicable, Joint Venture Agreement (JVA) in accordance with RA 4566.

Each partner of the Joint Venture shall submit their respective PhilGEPS Certificates of Registration in accordance with Section 8.5.2 of the revised IRR of RA 9184. The submission of technical and financial eligibility documents by any of the joint venture partners constitutes compliance: *Provided*, That the partner responsible to submit the NFCC shall likewise submit the Statement of all of its ongoing contracts and Audited Financial Statements.

The prospective bidders shall declare its Joint Venture partner during the purchase of bid/tender documents. Any single bidder/s who already procured/secured the bidding documents but want to avail the Joint Venture Agreement (JVA) shall inform the BAC in writing prior to the bid opening for records and documentation purposes. Failure to do so shall be a ground for disqualification/non-acceptance of its bid.

(b) Technical Documents –

- (i) Project Requirements, which shall include the following:

(i.1) Organizational chart for the contract to be bid;

(i.2) List of contractor's personnel to be assigned to the contract to be bid, with their complete qualification and experience data. These personnel must meet the required minimum years of experience, as follows:

**a. One (1) Project Engineer**

Registered Civil Engineer who had supervised at least a project similar in nature as to the type and cost of the proposed project within the last 10 years. Must have at least 5 years professional experience as Civil Engineer on similar project.

**b. One (1) Materials Engineer**

Registered Civil Engineer with valid accreditation from the Department of Public Works and Highways (DPWH) as Materials Engineer I

**c. One (1) Safety Officer 2**

Construction Safety Officer who has completed at least forty (40) hours of Construction Safety and Health Training (COSH) from Occupational Safety and Health Center (OSHC) or Safety Training Organizations (STOs) accredited by the Department of Labor and Employment (DOLE)

Valid Professional Regulations Commission (PRC) license for professional personnel, Construction Safety and Health Training Certificate from OSHC/STOs accredited by DOLE for the Safety Officer, certificate of accreditation including ID card issued by DPWH for Materials Engineer, shall be submitted and included as an attachment in the Standard Form NPCSF-INFR-09: List of Key Personnel Proposed to be Assign to the Contract.

The above key personnel must either be employed by the Bidder or contracted by the Bidder to be employed for the contract to be bid.

- (i.3) List of contractor's major equipment units, which are owned, leased, and/or under purchase agreements, supported by proof of ownership, certification of availability of equipment from the equipment lessor/vendor for the duration of the project, as the case may be, which must meet the minimum requirements for the contract, as follows:
- a. Pile Driving Equipment (Barge Mounted) - 1 unit complete with 4.5Ton ram weight, 25 ton drop hammer & 40-50Ton capacity crane
  - b. Deck Barge (800 to 1000DWT) - 1 unit
  - c. Welding Machine (500 Amp). - 1 unit
  - d. Concrete Mixer (2-bagger) - 1 unit
  - e. Bar Cutter (32mmΦ capable) - 1 unit
  - f. Portable Generator - 1 unit
  - g. Oxy-acetylene Cutting Outfit - 1 unit
  - h. Concrete Vibrator - 1 unit
  - i. Cargo Truck - 1 unit
  - j. Service Vehicle - 1 unit
- (ii) Omnibus Sworn statement in accordance with Section 25.3 of the IRR of RA 9184 and using the form prescribed in Section V – Bidding Forms.
- (iii) Complete eligibility documents of the proposed sub-contractor, if any.

## 12. Documents Comprising the Bid: Financial Component

12.1. The bidder shall submit the following requirements in their second envelope, financial component of their bid:

- (a) Duly signed Bid Letter indicating the total bid amount in accordance with the prescribed form (*Section V – Bidding Forms, NPCSF-INFR-13*);
- (b) Duly signed and completely filled-out Bill of Quantities (*Section V – Bill of Quantities*) indicating the unit and total prices per item and the total amount in the prescribed Bill of Quantities form;

- (c) Duly Signed Detailed Estimates for each items of work showing the computations in arriving at each item's unit prices used in coming up with the bid (*Section V – Bidding Forms, NPCSF-INFR-14*);
- (d) Summary sheets indicating the direct unit prices of construction materials, labor rates and equipment rental rates used in coming up with the bid (*Section V – Bidding Forms, NPCSF-INFR-15*).

12.2. Price proposals that exceed the ABC shall be rejected.

### 13. Alternative Bids

- 13.1. Alternative Bids shall be rejected. For this purpose, alternative bid is an offer made by a Bidder in addition or as a substitute to its original bid which may be included as part of its original bid or submitted separately therewith for purposes of bidding. A bid with options is considered an alternative bid regardless of whether said bid proposal is contained in a single envelope or submitted in two (2) or more separate bid envelopes.
- 13.2. Bidders shall submit offers that comply with the requirements of the Bidding Documents, including the basic technical design as indicated in the drawings and specifications.
- 13.3. Each Bidder shall submit only one Bid, either individually or as a partner in a JV. A Bidder who submits or participates in more than one bid (other than as a subcontractor if a subcontractor is permitted to participate in more than one bid) will cause all the proposals with the Bidder's participation to be disqualified. This shall be without prejudice to any applicable criminal, civil and administrative penalties that may be imposed upon the persons and entities concerned.

### 14. Bid Prices

- 14.1. The contract shall be for the whole Works, as described in ITB Clause 1.4 based on the priced Bill of Quantities submitted by the Bidder.
- 14.2. The Bidder shall fill in rates and prices for all items of the Works described in the Bill of Quantities. Bids not addressing or providing all of the required items in the Bidding Documents including, where applicable, Bill of Quantities, shall be considered non-responsive and, thus, automatically disqualified. In this regard, where a required item is provided, but no price is indicated, the same shall be considered as non-responsive, but specifying a zero (0) or a dash (-) for the said item would mean that it is being offered for free to the Government, except those required by law or regulations to be provided for.
- 14.3. All duties, taxes, and other levies payable by the Contractor under the Contract, or for any other cause, prior to the deadline for submission of bids, shall be included in the rates, prices, and total bid price submitted by the Bidder.
- 14.4. All bid prices for the given scope of work in the contract as awarded shall be considered as fixed prices, and therefore not subject to price escalation during contract implementation, except under extraordinary circumstances as specified in GCC Clause 46. Upon the recommendation of NPC, price escalation may be allowed in extraordinary circumstances as may be determined by the National Economic and Development Authority in

accordance with the Civil Code of the Philippines, and upon approval by the GPPB. Furthermore, in cases where the cost of the awarded contract is affected by any applicable new laws, ordinances, regulations, or other acts of the GoP, promulgated after the date of bid opening, a contract price adjustment shall be made or appropriate relief shall be applied on a no loss-no gain basis.

**15. Bid Currencies**

All bid prices shall be quoted in Philippine Pesos. Payment of the contract price shall also be made in Philippine Pesos.

**16. Bid Validity**

16.1. Bids shall remain valid for the period of **ONE HUNDRED TWENTY (120) CALENDAR DAYS** from the date of the opening of bids.

16.2. In exceptional circumstances, prior to the expiration of the bid validity period, NPC may request Bidders to extend the period of validity of their bids. The request and the responses shall be made in writing. A Bidder may refuse the request, but his bid shall no longer be considered for further evaluation and award. A Bidder granting the request shall not be required or permitted to modify its bid.

**17. Format and Signing of Bids**

17.1. Bidders shall submit their bids through their duly authorized representative using the appropriate forms provided in **Section V – Bidding Forms** on or before the deadline specified in the **ITB Clause 19** in two (2) separate sealed bid envelopes, and which shall be submitted simultaneously. The first shall contain the technical component of the bid, including the eligibility requirements under **ITB Clause 12.1**, and the second shall contain the financial component of the bid. This shall also be observed for each lot in the case of lot procurement.

17.2. Forms as mentioned in **ITB Clause 17.1** must be completed without any alterations to their format, and no substitute form shall be accepted. All blank spaces shall be filled in with the information requested.

17.3. The Bidder shall prepare and submit an original of the first and second envelopes as described in **ITB Clauses 12 and 13**.

17.4. Each and every page of the original bid must be authenticated with original signatures (preferably in blue or red ink) by the bidder or his duly authorized representative/s. Failure to do so shall be a ground for the rejection of the bid.

17.5. Any interlineations, erasures, or overwriting shall be valid only if they are signed or initialed by the duly authorized representative/s of the Bidder.

**18. Sealing and Marking of Bids**

18.1. Each Bidder shall submit one copy of the first and second components of its Bid.

The Procuring Entity may request additional hard copies and/or electronic copies of the Bid. However, failure of the Bidders to comply with the said request shall not be a ground for disqualification

If the Procuring Entity allows the submission of bids through online submission to the given website or any other electronic means, the Bidder shall submit an electronic copy of its Bid, which must be digitally signed. An electronic copy that cannot be opened or is corrupted shall be considered non-responsive and, thus, automatically disqualified.

18.2. All envelopes shall:

- (a) contain the name of the contract to be bid in capital letters;
- (b) bear the name and address of the Bidder in capital letters;
- (c) be addressed to NPC's BAC in accordance with ITB Clause 1.2;
- (d) bear the specific identification of this bidding process; and
- (e) bear a warning "DO NOT OPEN BEFORE..." the date and time for the opening of bids, in accordance with ITB Clause 19.

18.3. Unsealed or unmarked bid envelopes shall be rejected. However, bid envelopes that are not properly sealed and marked, as required in the bidding documents, shall not be rejected, but the Bidder or its duly authorized representative shall acknowledge such condition of the bid as submitted. The BAC or NPC shall assume no responsibility for the misplacement of the contents of the improperly sealed or marked bid, or for its premature opening.

### C. Submission and Opening of Bids

#### 19. Deadline for Submission of Bids

- 19.1. Proposals must be received by the BAC on the date and time agreed upon during negotiation meeting.
- 19.2. Any proposal submitted after the deadline for submission and receipt of proposals shall be declared "Late" and shall not be accepted by NPC.

#### 20. Opening and Preliminary Examination of Bids

- 20.1. The BAC shall open the Bids in public, immediately after the deadline for the submission and receipt of bids. In case the Bids cannot be opened as scheduled due to justifiable reasons, the BAC shall take custody of the Bids submitted and reschedule the opening of Bids on the next working day or at the soonest possible time through the issuance of a Notice of Postponement to be posted in the PhilGEPS website and the website of NPC.
- 20.2. The BAC shall open the first bid envelopes and determine each Bidder's compliance with the documents prescribed in ITB Clause 12, using a non-discretionary "pass/fail" criterion. If a Bidder submits the required document, it shall be rated "passed" for that particular requirement. In this regard, bids that fail to include any requirement or are incomplete or patently insufficient shall

- be considered as "failed". Otherwise, the BAC shall rate the said first bid envelope as "passed".
- 20.3. Immediately after determining compliance with the requirements in the first envelope, the BAC shall forthwith open the second bid envelope of each remaining eligible Bidder whose first bid envelope was rated "passed." The second envelope of each complying Bidder shall be opened within the same day. In case one or more of the requirements in the second envelope of a particular bid is missing, incomplete or patently insufficient, and/or if the submitted total bid price exceeds the ABC, the BAC shall rate the bid concerned as "failed." Only bids that are determined to contain all the bid requirements for both components shall be rated "passed" and shall immediately be considered for evaluation and comparison.
  - 20.4. Letters of Withdrawal shall be read out and recorded during bid opening, and the envelope containing the corresponding withdrawn bid shall be returned to the Bidder unopened.
  - 20.5. All members of the BAC who are present during bid opening shall initial every page of the original copies of all bids received and opened.
  - 20.6. Each partner of a joint venture agreement shall likewise submit the document required in **ITB** Clause 12.1(a)(i). Submission of other documents required under **ITB** Clause 12.1 by any of the joint venture partners constitutes compliance.
  - 20.7. NPC shall prepare the minutes of the proceedings of the bid opening that shall include, as a minimum: (a) names of Bidders, their bid price (per lot, if applicable, and/or including discount, if any), bid security, findings of preliminary examination, and whether there is a withdrawal or modification; and (b) attendance sheet. The BAC members shall sign the abstract of bids as read.
  - 20.8. The Bidders or their duly authorized representatives may attend the opening of bids. The BAC shall ensure the integrity, security, and confidentiality of all submitted bids. The Abstract of Bids as read and the minutes of the Bid Opening shall be made available to the public upon written request and payment of a specified fee to recover cost of materials.
  - 20.9. To ensure transparency and accurate representation of the bid submission, the BAC Secretariat shall notify in writing all Bidders whose bids it has received through its PhilGEPS-registered physical address or official e-mail address. The notice shall be issued within seven (7) calendar days from the date of the bid opening.

#### **D. Evaluation and Comparison of Bids**

#### **21. Process to be Confidential**

- 21.1. Members of the BAC, including its staff and personnel, as well as its Secretariat and TWG, are prohibited from making or accepting any kind of communication with any Bidder regarding the evaluation of their bids until the issuance of the Notice of Award, unless otherwise allowed in the case of **ITB** Clause 26.

- 21.2. Any effort by a Bidder to influence NPC in its decision in respect of bid evaluation, bid comparison or contract award will result in the rejection of the Bidder's bid.

**22. Clarification of Bids**

To assist in the evaluation, comparison and post-qualification of the bids, NPC may ask in writing any Bidder for a clarification of its bid. All responses to requests for clarification shall be in writing. Any clarification submitted by a Bidder in respect to its bid and that is not in response to a request by NPC shall not be considered.

**23. Detailed Evaluation and Comparison of Bids**

- 23.1. NPC will undertake the detailed evaluation and comparison of Bids which have passed the opening and preliminary examination of Bids, pursuant to ITB Clause 24, in order to determine the Lowest Calculated Bid.

- 23.2. The Lowest Calculated Bid shall be determined in two steps:

- (a) The detailed evaluation of the financial component of the bids, to establish the correct calculated prices of the bids; and
- (b) The ranking of the total bid prices as so calculated from the lowest to highest. The bid with the lowest price shall be identified as the Lowest Calculated Bid.

- 23.3. NPC's BAC shall immediately conduct a detailed evaluation of all bids rated "passed," using non-discretionary "pass/fail" criterion. The BAC shall consider the following in the evaluation of bids:

- (a) Completeness of the bid. Bids not addressing or providing all of the required items in the Schedule of Requirements including, where applicable, bill of quantities, shall be considered non-responsive and, thus, automatically disqualified. In this regard, where a required item is provided, but no price is indicated, the same shall be considered as non-responsive, but specifying a zero (0) or a dash (-) for the said item would mean that it is being offered for free to NPC, except those required by law or regulations to be provided for; and
- (b) Arithmetical corrections. Consider computational errors and omissions to enable proper comparison of all eligible bids. It may also consider bid modifications. Any adjustment shall be calculated in monetary terms to determine the calculated prices.

In case of discrepancies between:

1. bid prices in figures and in words, the latter shall prevail;
2. total price per item and unit price for the item as extended or multiplied by the quantity of that item, the latter shall prevail;
3. the total Bid amount and the sum of total costs per item, the sum of the total costs per item shall prevail and the total Bid amount will be corrected;

4. unit cost in the detailed estimate and unit cost in the Bid Price Schedule, the latter shall prevail;
- 23.4. Based on the detailed evaluation of bids, those that comply with the above-mentioned requirements shall be ranked in the ascending order of their total calculated bid prices, as evaluated and corrected for computational errors, discounts and other modifications, to identify the Lowest Calculated Bid. Total calculated bid prices, as evaluated and corrected for computational errors, discounts and other modifications, which exceed the ABC shall not be considered.
- 23.5. NPC's evaluation of bids shall be based on the bid price quoted in the Bid Letter, which includes the Bill of Quantities.
- 23.6. Bids shall be evaluated on an equal footing to ensure fair competition. For this purpose, all Bidders shall be required to include in their bids the cost of all taxes, such as, but not limited to, value added tax (VAT), income tax, local taxes, and other fiscal levies and duties which shall be itemized in the bid form and reflected in the detailed estimates. Such bids, including said taxes, shall be the basis for bid evaluation and comparison.
- 23.7. Partial bid is not allowed. The infrastructure project is packaged in a single lot and the lot shall not be divided into sub-lots for the purpose of bidding, evaluation, and contract award.

#### **24. Post Qualification**

- 24.1. The BAC shall determine to its satisfaction whether the Bidder that is evaluated as having submitted the Lowest Calculated Bid complies with and is responsive to all the requirements and conditions specified in ITB Clauses 5, 12, and 12.
- 24.2. Within a non-extendible period of five (5) calendar days from receipt by the Bidder of the notice from the BAC that it submitted the Lowest Calculated Bid, the Bidder shall submit its latest income and business tax returns filed and paid through the BIR Electronic Filing and Payment System (eFPS) and other documents and appropriate licenses and permits required by law, as follows:
  - a. Latest Income Tax Returns filed and paid through the BIR Electronic Filing and Payment System (eFPS);
  - b. Business Tax/VAT Returns within the last six (6) months preceding the date of the bid submission, filed and paid through the BIR (eFPS);
  - c. PhilGEPS Registration (Platinum Membership), if not yet submitted with the bid;
  - d. Valid and current Mayor's/Business, if under renewal during bidding;
  - e. Contract/Purchase Order and/or Notice of Award for the contracts stated in the List of all Ongoing Government & Private Contracts Including Contracts Awarded but not yet Started (NPCSF-INFR-02);
  - f. Certification coming from the project owner/client that the performance is satisfactory as of the bidding date for all ongoing contracts stated in form NPCSF-INFR-02;



- g. The licenses and permits relevant to the Project and the corresponding law requiring it as specified in the Technical Specifications, if any.

Failure to submit any of the post-qualification requirements on time, or a finding against the veracity thereof, shall disqualify the Bidder for award.

- 24.3. The determination shall be based upon an examination of the documentary evidence of the Bidder's qualifications submitted pursuant to ITB Clauses 12 and 12, as well as other information as NPC deems necessary and appropriate, using a non-discretionary "pass/fail" criterion, which shall be completed within a period of twelve (12) calendar days.
- 24.4. The post-qualification shall verify, validate, and ascertain all statements made and documents submitted by the bidder with the Lowest Calculated Bid/Highest Rated Bid, using non-discretionary criteria, as stated in the Bidding documents. These criteria shall consider, but shall not be limited to, the following:
- a) Legal Requirements. To verify, validate, and ascertain licenses, certificates, permits, and agreements submitted by the bidder, and the fact that it is not included in any "blacklist" as provided in Section 25.3 of IRR-A of R.A. 9184.
  - b) Technical Requirements. To determine compliance of the infrastructure projects offered with the requirements specified in the Bidding Documents, including, where applicable:
    - i) Verification and validation of the bidder's stated competence and experience, and the competence and experience of the bidder's key personnel to be assigned to the project.
    - ii) Verification of availability and commitment, and/or inspection and testing for the required capacities and operating conditions, of equipment units to be owned/leased/under purchase by the bidder for use in the contract under bidding, as well as checking the performance of the bidder in its ongoing government and private contracts, if any of these ongoing contracts shows:
      - a. Negative slippage of at least fifteen percent (15%) in any one project or a negative slippage of at least ten percent (10%) in each of two (2) or more contracts;
      - b. Failure of the contractor to commence repair works on ongoing contracts within seven (7) calendar days and to complete them within thirty (30) calendar days after receipt of NPC's notice of defects and deficiencies;
      - c. Failure of the contractor to commence repair works on contracts with pending certificates of acceptance within thirty (30) calendar days and complete them within ninety (90) days after receipt of NPC's notice of defects and failures; or
      - d. Substandard quality of work as per contract plans and specifications, or unsatisfactory performance of the contractor's obligations as per contract terms and conditions, at the time of inspection.

- iii) Verification and/or inspection and testing of the goods/product, after-sales and/or maintenance capabilities, in applicable cases, as well as checking the following:
  - a. Delay in the partial delivery of goods amounting to ten percent (10%) of the contract price in its ongoing government and private contracts;
  - b. If any of these contracts shows the bidder's failure to deliver or perform any or all of the goods or services within the period(s) specified in the contract or within any extension thereof granted by NPC pursuant to a request made by the supplier prior to the delay, and such failure amounts to at least ten percent (10%) of the contract price; or
  - c. Unsatisfactory performance of the supplier's obligations as per contract terms and conditions at the time of inspection

If the BAC verifies any of these deficiencies to be due to the contractor's fault or negligence, the agency shall disqualify the contractor from the award.

- iv) Ascertainment of the authenticity of the bid security and its correctness as to type, amount, form and wording, and validity period, as required in the Bidding Documents.
- c) Financial Requirements. To verify, validate and ascertain the bid price proposal of the bidder and the bidder's NFCC to ensure that the bidder can sustain the operating cash flow of the transaction.
- 24.5. If the BAC determines that the Bidder with the Lowest Calculated Bid passes all the criteria for post-qualification, it shall declare the said bid as the LCRB, and recommend to the Head of NPC the award of contract to the said Bidder at its submitted price or its calculated bid price, whichever is lower, subject to ITB Clause 26.3.
- 24.6. A negative determination shall result in rejection of the Bidder's bid, in which event NPC shall proceed to the next Lowest Calculated Bid, with a fresh period to make a similar determination of that Bidder's capabilities to perform satisfactorily. If the second Bidder, however, fails the post qualification, the procedure for post qualification shall be repeated for the Bidder with the next Lowest Calculated Bid, and so on until the LCRB is determined for recommendation of contract award.
- 24.7. Within a period not exceeding fifteen (15) calendar days from the determination by the BAC of the LCRB and the recommendation to award the contract, the Head of NPC or his duly authorized representative shall approve or disapprove the said recommendation.
- 24.8. In the event of disapproval, which shall be based on valid, reasonable, and justifiable grounds as provided for under Section 41 of the IRR of RA 9184, the Head of NPC shall notify the BAC and the Bidder in writing of such decision and the grounds for it. When applicable, the BAC shall conduct a post-qualification of the Bidder with the next Lowest Calculated Bid. A request for

reconsideration may be filed by the Bidder with the Head of NPC in accordance with Section 37.1.3 of the IRR of RA 9184.

## 25. Reservation Clause

- 25.1. Notwithstanding the eligibility or post-qualification of a Bidder, NPC reserves the right to review its qualifications at any stage of the procurement process if it has reasonable grounds to believe that a misrepresentation has been made by the said Bidder, or that there has been a change in the Bidder's capability to undertake the project from the time it submitted its eligibility requirements. Should such review uncover any misrepresentation made in the eligibility and bidding requirements, statements or documents, or any changes in the situation of the Bidder which will affect its capability to undertake the project so that it fails the preset eligibility or bid evaluation criteria, NPC shall consider the said Bidder as ineligible and shall disqualify it from submitting a bid or from obtaining an award or contract.
- 25.2. Based on the following grounds, NPC reserves the right to reject any and all Bids, declare a Failure of Bidding at any time prior to the contract award, or not to award the contract, without thereby incurring any liability, and make no assurance that a contract shall be entered into as a result of the bidding:
- (a) If there is *prima facie* evidence of collusion between appropriate public officers or employees of NPC, or between the BAC and any of the Bidders, or if the collusion is between or among the Bidders themselves, or between a Bidder and a third party, including any act which restricts, suppresses or nullifies or tends to restrict, suppress or nullify competition;
  - (b) If NPC's BAC is found to have failed in following the prescribed bidding procedures; or
  - (c) For any justifiable and reasonable ground where the award of the contract will not redound to the benefit of the GOP as follows:
    - (i) If the physical and economic conditions have significantly changed so as to render the project no longer economically, financially or technically feasible as determined by the head of NPC;
    - (ii) If the project is no longer necessary as determined by head of NPC; and
    - (iii) If the source of funds for the project has been withheld or reduced through no fault of NPC.
- 25.3. In addition, NPC may likewise declare a failure of bidding when:
- (a) No bids are received;
  - (b) All prospective Bidders are declared ineligible;
  - (c) All bids fail to comply with all the bid requirements, fail post-qualification; or

- (d) The Bidder with the LCRB refuses, without justifiable cause, to accept the award of contract, and no award is made in accordance with Section 40 of the IRR of RA 9184.

### E. Award of Contract

#### 26. Contract Award

- 26.1. Subject to **ITB** Clause 24, the head of NPC or its duly authorized representative shall award the contract to the Bidder whose bid has been determined to be the LCRB, at its submitted price or its calculated bid price, whichever is lower.
- 26.2. Prior to the expiration of the period of bid validity, NPC shall notify the successful Bidder in writing that its bid has been accepted, through a Notice of Award duly received by the Bidder or its representative personally or by registered mail or electronically, receipt of which must be confirmed in writing within two (2) days by the Bidder with the LCRB and submitted personally or sent by registered mail or electronically to NPC.
- 26.3. Notwithstanding the issuance of the Notice of Award, award of contract shall be subject to the following conditions:
- (a) Submission of the following documents within ten (10) calendar days from receipt of the Notice of Award:
    - (i) In the case of procurement by a Philippine Foreign Service Office or Post, the PhilGEPS Registration Number of the winning foreign Bidder; or
    - (ii) Valid PCAB license and registration for the type and cost of the contract to be bid for foreign bidders when the Treaty or International or Executive Agreement expressly allows submission of the PCAB license and registration for the type and cost of the contract to be bid as a pre-condition to the Award;
  - (b) Posting of the performance security in accordance with **ITB** Clause 28;
  - (c) Signing of the contract as provided in **ITB** Clause 27; and
  - (d) Approval by higher authority, if required, as provided in Section 37.3 of the IRR of RA 9184.

#### 27. Signing of the Contract

- 27.1. At the same time as NPC notifies the successful Bidder that its bid has been accepted, NPC shall send the Contract Form to the Bidder, which Contract has been provided in the Bidding Documents, incorporating therein all agreements between the parties.
- 27.2. Within ten (10) calendar days from receipt of the Notice of Award, the successful Bidder shall post the required performance security, sign and date the contract and return it to NPC.

- 27.3. NPC shall enter into contract with the successful Bidder within the same ten (10) calendar day period provided that all the documentary requirements are complied with.
- 27.4. The following documents shall form part of the contract:
- (a) Contract Agreement;
  - (b) Bidding Documents;
  - (c) Winning Bidder's bid, including the Technical and Financial Proposals, and all other documents/statements submitted (e.g., Bidder's response to request for clarifications on the bid), including corrections to the bid, if any, resulting from NPC's bid evaluation;
  - (d) Performance Security;
  - (e) Notice of Award of Contract;
  - (f) Notice to Proceed;
  - (g) Construction schedule and S-curve;
  - (h) Manpower Schedule;
  - (i) Construction Methods;
  - (j) Equipment Utilization Schedule;
  - (k) Construction safety and health program of the contractor duly approved by the Bureau of Working Condition (BWC) of the Department of Labor and Employment (DOLE) or proof of submission to BWC ;
  - (l) PERT/CPM;
  - (m) Other contract documents that may be required by existing laws and/or NPC under these Bidding Documents

## 28. Performance Security

28.1. To guarantee the faithful performance by the winning Bidder of its obligations under the contract, it shall post a performance security within a maximum period of ten (10) calendar days from the receipt of the Notice of Award from NPC and in no case later than the signing of the contract.

28.2. The Performance Security shall be denominated in Philippine Pesos and posted in favor of NPC in an amount not less than the percentage of the total contract price in accordance with the following schedule:

Form of Performance Security	Amount of Performance Security (Not less than the Percentage of the Total Contract Price)
------------------------------	---

(b) Cash or cashier's/manager's check issued by a Universal or Commercial Bank.	Ten percent (10%)
(c) Bank draft/guarantee or irrevocable letter of credit issued by a Universal or Commercial Bank: Provided, however, that it shall be confirmed or authenticated by a Universal or Commercial Bank, if issued by a foreign bank.	
(d) Surety bond callable upon demand issued by a surety or insurance company duly certified by the Insurance Commission as authorized to issue such security.	Thirty percent (30%)

28.3. Failure of the successful Bidder to comply with the above-mentioned requirement shall constitute sufficient ground for the annulment of the award and forfeiture of the bid security, in which event NPC shall have a fresh period to initiate and complete the post qualification of the second Lowest Calculated Bid. The procedure shall be repeated until LCRB is identified and selected for recommendation of contract award. However if no Bidder passed post-qualification, the BAC shall declare the bidding a failure and conduct a re-bidding with re-advertisement, if necessary.

28.4. The performance bond to be posted by the Contractor must also comply with the following additional requirements:

1. The following must be indicated in the performance bond to be posted by the Contractor:
  - i. Company Name
  - ii. Correct amount of the Bond
  - iii. Contract/Purchase Order Reference Number
  - iv. Purpose of the Bond:

"To guarantee the faithful performance of the Principal's obligation to undertake (Contract/Purchase Order Description) in accordance with the terms and conditions of (Contract No. & Schedule/Purchase Order No.) entered into by the parties."

2. The bond shall remain valid and effective until the duration of the contract (should be specific date reckoned from the contract effectivity) plus sixty (60) days after NPC's acceptance of the last delivery/final acceptance of the project.
3. In case of surety bond, any extension of the contract duration or delivery period granted to the CONTRACTOR shall be considered as given, and any modification of the contract shall be considered as authorized, as if with the expressed consent of the surety, provided that such extension or

modifications falls within the effective period of the said surety bond. However, in the event that the extension of the contract duration or delivery schedule would be beyond the effective period of the surety bond first posted, it shall be the sole obligation of the CONTRACTOR to post an acceptable Performance Security within ten (10) calendar days after the contract duration/delivery period extension has been granted by NPC.

4. Other required conditions in addition to the standard policy terms issued by the Bonding Company:
  - a) The bond is a penal bond, callable on demand and the entire amount thereof shall be forfeited in favor of the Obligee upon default of the Principal without the need to prove or to show grounds or reasons for demand for the sum specified therein;
  - b) The amount claimed by the Obligee under this bond shall be paid in full and shall never be subject to any adjustment by the Surety;
  - c) In case of claim, the Surety shall pay such claim within sixty (60) days from receipt by the Surety of the Obligee's notice of claim/demand letter notwithstanding any objection thereto by the Principal.

#### **29. Notice to Proceed**

Within seven (7) calendar days from the date of approval of the Contract by the appropriate government approving authority, NPC shall issue the Notice to Proceed (NTP) together with a copy or copies of the approved contract to the successful Bidder. All notices called for by the terms of the contract shall be effective only at the time of receipt thereof by the successful Bidder.

#### **30. Protest Mechanism**

Decision of NPC at any stage of the procurement process may be questioned in accordance with Sections 55 of the IRR of RA 9184.

## SECTION II

# GENERAL CONDITIONS OF CONTRACT





**SECTION II – GENERAL CONDITIONS OF CONTRACT****TABLE OF CONTENTS**

CLAUSE NO.	TITLE	PAGE NO.
1.	Definitions.....	1
2.	Interpretation .....	3
3.	Governing Language and Law .....	4
4.	Communications .....	4
5.	Possession of Site .....	4
6.	The Contractor's Obligations.....	4
7.	Performance Security .....	7
8.	Subcontracting.....	7
9.	Liquidated Damages.....	8
10.	NPC, Licenses and Permits .....	8
11.	Contractor's Risk and Warranty Security.....	8
12.	Liability of the Contractor .....	11
13.	NPC's Risk .....	11
14.	Insurance.....	11
15.	Termination for Default of Contractor .....	12
16.	Termination for Default of NPC .....	13
17.	Termination for Other Causes.....	13
18.	Procedures for Termination of Contracts.....	15
19.	Force Majeure, Release From Performance .....	17
20.	Resolution of Disputes .....	17
21.	Suspension of Loan, Credit, Grant, or Appropriation.....	18
22.	Procuring Entity's Representative's Decisions .....	18
23.	Approval of Drawings and Temporary Works by NPC's Representative .....	18
24.	Acceleration and Delays Ordered by NPC's Representative .....	18
25.	Extension of the Intended Completion Date .....	19
26.	Right to Vary.....	19
27.	Contractor's Right to Claim .....	19
28.	Early Warning .....	19
29.	Program of Work.....	20
30.	Management Conferences.....	20
31.	Bill of Quantities.....	20
32.	Instructions, Inspections and Audits.....	21

33. Identifying Defects .....	22
34. Cost of Repairs .....	22
35. Correction of Defects .....	22
36. Uncorrected Defects .....	22
37. Advance Payment.....	22
38. Progress Payments .....	23
39. Payment Certificates.....	23
40. Retention .....	24
41. Variation Orders.....	24
42. Contract Completion.....	26
43. Suspension of Work.....	26
44. Payment on Termination.....	27
45. Extension of Contract Time.....	27
46. Price Adjustment.....	28
47. Completion .....	28
48. Taking Over .....	28
49. Operating and Maintenance Manuals .....	29

## SECTION II – GENERAL CONDITIONS OF CONTRACT

### 1. Definitions

For purposes of this Clause, boldface type is used to identify defined terms.

- 1.1. The **Arbiter** is the person appointed jointly by NPC and the Contractor to resolve disputes in the first instance, as provided for in **GCC Clause 20**.
- 1.2. **Bill of Quantities** refers to a list of the specific items of the Work and their corresponding unit prices, lump sums, and/or provisional sums.
- 1.3. The **Completion Date** is the date of completion of the Works as certified by NPC's Representative, in accordance with **GCC Clause 47**.
- 1.4. The **Contract** is the contract between NPC and the Contractor to execute, complete, and maintain the Works.
- 1.5. The **Contract Effectivity Date** is the date of signing of the Contract. However, the contractor shall commence execution of the Works on the Start Date as defined in **GCC Clause 1.28**.
- 1.6. The **Contract Price** is the price stated in the Notice of Award and thereafter to be paid by NPC to the Contractor for the execution of the Works in accordance with this Contract
- 1.7. **Contract Time Extension** is the allowable period for the Contractor to complete the Works in addition to the original Completion Date stated in this Contract.
- 1.8. The **Contractor** is the juridical entity whose proposal has been accepted by NPC and to whom the Contract to execute the Work was awarded.
- 1.9. The **Contractor's Bid** is the signed offer or proposal submitted by the Contractor to NPC in response to the Bidding Documents.
- 1.10. **Days** are calendar days; months are calendar months.
- 1.11. **Dayworks** are varied work inputs subject to payment on a time basis for the Contractor's employees and Equipment, in addition to payments for associated Materials and Plant.
- 1.12. A **Defect** is any part of the Works not completed in accordance with the Contract.
- 1.13. The **Defects Liability Certificate** is the certificate issued by NPC's Representative upon correction of defects by the Contractor.
- 1.14. The **Defects Liability Period** is the one year period between contract completion and final acceptance within which the Contractor assumes the responsibility to undertake the repair of any damage to the Works at his own expense.

- 1.15 **Drawings** are graphical presentations of the Works. They include all supplementary details, shop drawings, calculations, and other information provided or approved for the execution of this Contract.
- 1.16 **Equipment** refers to all facilities, supplies, appliances, materials or things required for the execution and completion of the Work provided by the Contractor and which shall not form or are not intended to form part of the Permanent Works.
- 1.17 The **Intended Completion Date** refers to the period specified in Clause PH – 4.0 of Section III – Technical Specifications (PH – Project Highlights) when the Contractor is expected to have completed the Works. The Intended Completion Date may be revised only by NPC's Representative by issuing an extension of time or an acceleration order.
- 1.18 **Materials** are all supplies, including consumables, used by the Contractor for incorporation in the Works.
- 1.19 The **Notice to Proceed** is a written notice issued by NPC or NPC's Representative to the Contractor requiring the latter to begin the commencement of the work not later than a specified or determinable date.
- 1.20 **Permanent Works** are all permanent structures and all other project features and facilities required to be constructed and completed in accordance with this Contract which shall be delivered to NPC and which shall remain at the Site after the removal of all Temporary Works.
- 1.21 **Plant** refers to the machinery, apparatus, and the like intended to form an integral part of the Permanent Works.
- 1.22 NPC is the **National Power Corporation (NPC or NAPOCOR)** with office address at BIR Road cor. Quezon Avenue, Diliman, Quezon City.
- 1.23 NPC's **Representative** refers to the Head of NPC or his duly authorized representative, who shall be responsible for supervising the execution of the Works and administering this Contract.
- NPC's Representative is:
- ATTY. MELCHOR P. RIDULME**  
OIC, President and CEO  
National Power Corporation  
BIR Road corner Quezon Avenue  
Diliman, Quezon City 1100
- 1.24 The **Site** is the place provided by NPC, which is specified in Clause PH – 2.0 of Section III – Technical Specifications (PH – Project Highlights) where the Works shall be executed and any other place or places which may be designated or notified to the Contractor by NPC's Representative as forming part of the Site.
- 1.25 **Site Investigation Reports** are those that were included in the Bidding Documents and are factual and interpretative reports about the surface and subsurface conditions at the Site.

- 1.26 **Slippage** is a delay in work execution occurring when actual accomplishment falls below the target as measured by the difference between the scheduled and actual accomplishment of the Work by the Contractor as established from the work schedule. This is actually described as a percentage of the whole Works.
- 1.27 **Specifications** means the description of Works to be done and the qualities of materials to be used, the equipment to be installed and the mode of construction.
- 1.28 The **Start Date**, as specified in the Notice to Proceed (NTP), is the date when the Contractor is obliged to commence execution of the Works. It does not necessarily coincide with any of the Site Possession Dates.
- 1.29 A **Subcontractor** is any person or organization to whom a part of the Works has been subcontracted by the Contractor, as allowed by NPC, but not any assignee of such person.
- 1.30 **Temporary Works** are works designed, constructed, installed, and removed by the Contractor that are needed for construction or installation of the Permanent Works.
- 1.31 **Work(s)** refer to the Permanent Works and Temporary Works to be executed by the Contractor in accordance with this Contract, including (i) the furnishing of all labor, materials, equipment and others incidental, necessary or convenient to the complete execution of the Works; (ii) the passing of any tests before acceptance by NPC's Representative; (iii) and the carrying out of all duties and obligations of the Contractor imposed by this Contract as described in Clause PH – 3.0 of Section III – Technical Specifications (PH – Project Highlights).

## 2. Interpretation

- 2.1. In interpreting the Conditions of Contract, singular also means plural, male also means female or neuter, and the other way around. Headings have no significance. Words have their normal meaning under the language of this Contract unless specifically defined. NPC's Representative will provide instructions clarifying queries about the Conditions of Contract.
- 2.2. The documents forming this Contract shall be interpreted in the following order of priority:
- a) Contract Agreement;
  - b) Bid Data Sheet;
  - c) Instructions to Bidders;
  - d) Addenda to the Bidding Documents;
  - e) Special Conditions of Contract;
  - f) General Conditions of Contract;
  - g) Specifications;
  - h) Bill of Quantities; and

## i) Drawings.

**3. Governing Language and Law**

- 3.1. This Contract has been executed in the English language, which shall be the binding and controlling language for all matters relating to the meaning or interpretation of this Contract. All correspondence and other documents pertaining to this Contract which are exchanged by the parties shall be written in English.
- 3.2. This Contract shall be interpreted in accordance with the laws of the Republic of the Philippines.

**4. Communications**

Communications between parties that are referred to in the Conditions shall be effective only when in writing. A notice shall be effective only when it is received by the concerned party.

**5. Possession of Site**

- 5.1. NPC shall grant the Contractor possession of so much of the Site as may be required to enable it to proceed with the execution of the Works. If the Contractor suffers delay or incurs cost from failure on the part of NPC to give possession in accordance with the terms of this clause, NPC's Representative shall give the Contractor a Contract Time Extension and certify such sum as fair to cover the cost incurred, which sum shall be paid by NPC.
- 5.2. If possession of a portion is not given by the date stated, NPC will be deemed to have delayed the start of the relevant activities. The resulting adjustments in contract time to address such delay shall be in accordance with GCC Clause 45.
- 5.3. The Contractor shall bear all costs and charges for special or temporary right-of-way required by it in connection with access to the Site. The Contractor shall also provide at his own cost any additional facilities outside the Site required by it for purposes of the Works.
- 5.4. The Contractor shall allow NPC's Representative and any person authorized by NPC's Representative access to the Site and to any place where work in connection with this Contract is being carried out or is intended to be carried out.

**6. The Contractor's Obligations**

- 6.1. The Contractor shall carry out the Works properly and in accordance with this Contract. The Contractor shall provide all supervision, labor, Materials, Plant and Contractor's Equipment, which may be required. All Materials and Plant on Site shall be deemed to be the property of NPC.
- 6.2. The Contractor shall commence execution of the Works on the Start Date and shall carry out the Works in accordance with the Program of Work submitted by the Contractor, as updated with the approval of NPC's Representative, and complete them by the Intended Completion Date.

- 6.3. The Contractor shall be responsible for the safety of all activities on the Site.
- 6.4. The Contractor shall carry out all instructions of NPC's Representative that comply with the applicable laws where the Site is located.
- 6.5. The Contractor shall employ the key personnel named in the Schedule of Key Personnel, as referred to in ITB 12.1(b)(i.2), to carry out the supervision of the Works. NPC will approve any proposed replacement of key personnel only if their relevant qualifications and abilities are equal to or better than those of the personnel listed in the Schedule.
- 6.6. If NPC's Representative asks the Contractor to remove a member of the Contractor's staff or work force, for justifiable cause, the Contractor shall ensure that the person leaves the Site within seven (7) days and has no further connection with the Work in this Contract.
- 6.7. During Contract implementation, the Contractor and his subcontractors shall abide at all times by all labor laws, including child labor related enactments, and other relevant rules.
- 6.8. The Contractor shall submit to NPC for consent the name and particulars of the person authorized to receive instructions on behalf of the Contractor.
- 6.9. The Contractor shall cooperate and share the Site with other contractors, public authorities, utilities, and NPC between the dates given in the schedule of other contractors particularly when they shall require access to the Site. The Contractor shall also provide facilities and services for them during this period. NPC may modify the schedule of other contractors, and shall notify the Contractor of any such modification thereto.
- 6.10. Should anything of historical or other interest or of significant value be unexpectedly discovered on the Site, it shall be the property of NPC. The Contractor shall notify NPC's Representative of such discoveries and carry out NPC's Representative's instructions in dealing with them.
- 6.11. It shall also be the obligation and responsibility of the Contractor to carry out the Works properly and in accordance with this Contract, including but not limited to the following conditions:
- a. The Contractor shall conduct the Works with due regard to safety and health in accordance with its Construction Safety and Health Program (CSHP) duly approved by the Department of Labor & Employment (DOLE) and in compliance with the DOLE Department Order No. 13 – The Guidelines Governing Occupational Safety and Health in the Construction Industry.
- Failure to comply with the approved CSHP will be considered as non-compliance with the Contract and shall result to the imposition of Section 19, Violation and Penalties of the DOLE Department Order No. 13 and any appropriate sanctions such as, but not limited to:
1. Suspend the work until the Contractor complies with the approved CSHP with the condition that the work resumption will not incur additional cost to the Corporation;

2. Suspend payment of the portion of work under question;
  3. Correct the situation by employing 3<sup>rd</sup> party and charge all expenses incurred to the Contractor's collectibles/securities; and
  4. Report the condition to the Bureau of Working Conditions of the DOLE for their appropriate action.
- b. The Contractor shall be responsible for the strict compliance with the provision of the Philippine Laws affecting labor and operation of Work under the contract and shall be responsible for the payment of all indemnities arising out of any labor accident which may occur in the execution of the Works and for which he may be responsible under Republic Act 3428, as amended, known as the Workmen's Compensation Law.
  - c. The Contractor is obliged to exercise due care so as not to endanger life and property in the vicinity of the Works where he operates in connection with this Contract. He shall be liable for all damages incurred in any manner by acts of negligence of his own, or his agents, employees, or workmen.
  - d. It is the responsibility of the Contractor for the strict compliance with the requirements of the Philippine Clean Air Act of 1999 (R.A. 8749) and Philippine Clean Water Act of 2004 (R.A. 9275). The Contractor shall be liable for any damages/destructions to the environment including penalties that will be imposed by the Department of Environment and Natural Resources (DENR) arising from non-compliance of the requirements thereof.
  - e. The Contractor shall be responsible for the strict compliance with the requirements of the Environmental Compliance Certificate (ECC) issued for this project (if any) and DENR Administrative Order No. 26. He shall be liable for any damages/destructions to the environment including penalties that will be imposed by the DENR arising from non-compliance thereof, in any manner by his acts or negligence, or by his agents, employees, or workmen in the execution of the Works. The Contractor may employ a Pollution Control Officer accredited with the DENR for the duration of the project, if so required by the DENR Administrative Order No. 26
  - f. It shall be the Contractor's responsibility for the correctness, accuracy and quality of works. NPC's approval does not relieve his contractual obligation and responsibility under this contract.
  - g. Payment of all forms of taxes, such as value added tax (VAT) including municipal licenses and permits, and others that may be imposed by the Philippine Government or any of its agencies and political subdivisions in connection with the Contract shall be for the account of the Contractor.
  - h. In general, the Contractor is totally responsible for the execution of the Works and therefore, takes upon himself all the technical, legal and economic risks and all obligations which could arise therefrom or connected therewith. The overall responsibility of the Contractor includes the responsibility for actions or omissions of his own personnel as well as the personnel of the sub-contractors.



## 7. Performance Security

- 7.1. Within ten (10) calendar days from receipt of the Notice of Award from NPC but in no case later than the signing of the contract by both parties, the Contractor shall furnish the performance security in any of the forms prescribed in ITB Clause 28.2.
- 7.2. The performance security posted in favor of NPC shall be forfeited in the event it is established that the Contractor is in default in any of its obligations under the Contract.
- 7.3. The performance security shall remain valid until issuance by NPC of the Certificate of Final Acceptance.
- 7.4. The performance security may be released by NPC and returned to the Contractor after the issuance of the Certificate of Final Acceptance subject to the following conditions:
  - (a) There are no pending claims against the Contractor or the surety company filed by NPC;
  - (b) The Contractor has no pending claims for labor and materials filed against it;
- 7.5. The Contractor shall post an additional performance security following the amount and form specified in ITB Clause 28.2 to cover any cumulative increase of more than ten percent (10%) over the original value of the contract as a result of amendments to order or change orders, extra work orders and supplemental agreements, as the case may be. The Contractor shall cause the extension of the validity of the performance security to cover approved contract time extensions.
- 7.6. In case of a reduction in the contract value or for partially completed Works under the contract which are usable and accepted by NPC the use of which, in the judgment of the implementing agency or NPC, will not affect the structural integrity of the entire project, NPC shall allow a proportional reduction in the original performance security, provided that any such reduction is more than ten percent (10%) and that the aggregate of such reductions is not more than fifty percent (50%) of the original performance security.
- 7.7. The Contractor, by entering into the Contract with NPC, acknowledges the right of NPC to institute action pursuant to Act 3688 against any subcontractor be they an individual, firm, partnership, corporation, or association supplying the Contractor with labor, materials and/or equipment for the performance of this Contract.

## 8. Subcontracting

- 8.1. The Contractor cannot subcontract Works more than the percentage specified in ITB Clause 8.1.
- 8.2. Subcontracting of any portion of the Works does not relieve the Contractor of any liability or obligation under this Contract. The Contractor will be responsible for the acts, defaults, and negligence of any subcontractor, its agents, servants

or workmen as fully as if these were the Contractor's own acts, defaults, or negligence, or those of its agents, servants or workmen.

- 8.3. If subcontracting is allowed, the contractor may identify its subcontractor during contract implementation stage. Subcontractors disclosed and identified during the bidding may be changed during the implementation of this Contract. In either case, subcontractors must submit the documentary requirements under ITB Clause 12 and comply with the eligibility criteria specified in the ITB. In the event that any subcontractor is found by any NPC to be ineligible, the subcontracting of such portion of the Works shall be disallowed.

## 9. Liquidated Damages

- 9.1. The Contractor shall pay liquidated damages to NPC for each day that the Completion Date is later than the Intended Completion Date. The applicable liquidated damages is at least one-tenth (1/10) of a percent of the cost of the unperformed portion for every day of delay. NPC shall deduct liquidated damages from payments due to the Contractor. Payment of liquidated damages shall not affect the Contractor's liabilities. Once the cumulative amount of liquidated damages reaches ten percent (10%) of the amount of this Contract, NPC may rescind or terminate this Contract, without prejudice to other courses of action and remedies available under the circumstances.

- 9.2. If the Intended Completion Date is extended after liquidated damages have been paid, NPC shall correct any overpayment of liquidated damages by the Contractor by adjusting the next payment certificate.

## 10. NPC, Licenses and Permits

NPC shall, if requested by the Contractor, assist him in applying for permits, licenses or approvals, which are required for the Works.

## 11. Contractor's Risk and Warranty Security

- 11.1. The Contractor shall assume full responsibility for the Works from the time project construction commenced up to final acceptance by NPC and shall be held responsible for any damage or destruction of the Works except those occasioned by *force majeure*. The Contractor shall be fully responsible for the safety, protection, security, and convenience of his personnel, third parties, and the public at large, as well as the Works, Equipment, installation, and the like to be affected by his construction work.

- 11.2. The defects liability period for infrastructure projects shall be one year from contract completion up to final acceptance by NPC. During this period, the Contractor shall undertake the repair works, at his own expense, of any damage to the Works on account of the use of materials of inferior quality within ninety (90) days from the time the Head of NPC has issued an order to undertake repair. In case of failure or refusal to comply with this mandate, NPC shall undertake such repair works and shall be entitled to full reimbursement of expenses incurred therein upon demand.

- 11.3. In case the Contractor fails to comply with the preceding paragraph, NPC shall forfeit its performance security, subject its property(ies) to attachment or garnishment proceedings, and perpetually disqualify it from participating in any

public bidding. All payables of the GoP in his favor shall be offset to recover the costs.

- 11.4. After final acceptance of the Works by NPC, the Contractor shall be held responsible for "Structural Defects," *i.e.*, major faults/flaws/deficiencies in one or more key structural elements of the project which may lead to structural failure of the completed elements or structure, or "Structural Failures," *i.e.*, where one or more key structural elements in an infrastructure facility fails or collapses, thereby rendering the facility or part thereof incapable of withstanding the design loads, and/or endangering the safety of the users or the general public:
- (a) Contractor – Where Structural Defects/Failures arise due to faults attributable to improper construction, use of inferior quality/substandard materials, and any violation of the contract plans and specifications, the contractor shall be held liable;
  - (b) Consultants – Where Structural Defects/Failures arise due to faulty and/or inadequate design and specifications as well as construction supervision, then the consultant who prepared the design or undertook construction supervision for the project shall be held liable;
  - (c) NPC's Representatives/Project Manager/Construction Managers and Supervisors – The project owner's representative(s), project manager, construction manager, and supervisor(s) shall be held liable in cases where the Structural Defects/Failures are due to his/their willful intervention in altering the designs and other specifications; negligence or omission in not approving or acting on proposed changes to noted defects or deficiencies in the design and/or specifications; and the use of substandard construction materials in the project;
  - (d) Third Parties - Third Parties shall be held liable in cases where Structural Defects/Failures are caused by work undertaken by them such as leaking pipes, diggings or excavations, underground cables and electrical wires, underground tunnel, mining shaft and the like, in which case the applicable warranty to such structure should be levied to third parties for their construction or restoration works.
  - (e) Users - In cases where Structural Defects/Failures are due to abuse/misuse by the end user of the constructed facility and/or non-compliance by a user with the technical design limits and/or intended purpose of the same, then the user concerned shall be held liable.
- 11.5. The warranty against Structural Defects/Failures, except those occasioned on force majeure, shall cover the period specified below, reckoned from the date of issuance of the Certificate of Final Acceptance by NPC.

In case of permanent structures, such as buildings of types 4 and 5 as classified under the National Building Code of the Philippines and other structures made of steel, iron, or concrete which comply with relevant structural codes (e.g., DPWH Standard Specifications), such as, but not limited to, steel/concrete bridges, flyovers, aircraft movement areas, ports, dams, tunnels, filtration and treatment plants, sewerage systems, power plants, transmission and

communication towers, railway system, and other similar permanent structures: Fifteen (15) years.

In case of semi-permanent structures, such as buildings of types 1, 2, and 3 as classified under the National Building Code of the Philippines, concrete/asphalt roads, concrete river control, drainage, irrigation lined canals, river landing, deep wells, rock causeway, pedestrian overpass, and other similar semi-permanent structures: Five (5) years.

In case of other structures, such as Bailey and wooden bridges, shallow wells, spring developments, and other similar structures: Two (2) years.

- 11.6. The Contractor shall be required to put up a warranty security in the form of cash, bank guarantee, letter of credit, GSIS or surety bond callable on demand, in accordance with the following schedule:

Form of Warranty	Amount of Warranty Security Not less than the Percentage (%) of Total Contract Price
(a) Cash or letter of credit issued by Universal or Commercial bank: provided, however, that the letter of credit shall be confirmed or authenticated by a Universal or Commercial bank, if issued by a foreign bank	Five Percent (5%)
(b) Bank guarantee confirmed by Universal or Commercial bank: provided, however, that the letter of credit shall be confirmed or authenticated by a Universal or Commercial bank, if issued by a foreign bank	Ten Percent (10%)
(c) Surety bond callable upon demand issued by GSIS or any surety or insurance company duly certified by the Insurance Commission	Thirty Percent (30%)

- 11.7. The warranty security shall be stated in Philippine Pesos and shall remain effective for one year from the date of issuance of the Certificate of Final Acceptance by NPC, and returned only after the lapse of said one year period.
- 11.8. In case of structural defects/failure occurring during the applicable warranty period provided in GCC Clause 11.5, NPC shall undertake the necessary restoration or reconstruction works and shall be entitled to full reimbursement by the parties found to be liable for expenses incurred therein upon demand, without prejudice to the filing of appropriate administrative, civil, and/or criminal charges against the responsible persons as well as the forfeiture of the warranty security posted in favor of NPC.

**12. Liability of the Contractor**

The Contractor's liability under this Contract shall be as provided by the laws of the Republic of the Philippines. In case of Joint Venture, all partners to the joint venture shall be jointly and severally liable to NPC.

**13. NPC's Risk**

13.1. From the Start Date until the Certificate of Final Acceptance has been issued, the following are risks of NPC:

- (a) The risk of personal injury, death, or loss of or damage to property (excluding the Works, Plant, Materials, and Equipment), which are due to:
  - (i) any type of use or occupation of the Site authorized by NPC after the official acceptance of the works; or
  - (ii) negligence, breach of statutory duty, or interference with any legal right by NPC or by any person employed by or contracted to him except the Contractor.
- (b) The risk of damage to the Works, Plant, Materials, and Equipment to the extent that it is due to a fault of NPC or in NPC's design, or due to war or radioactive contamination directly affecting the country where the Works are to be executed.

**14. Insurance**

14.1. The Contractor shall, under his name and at his own expense, obtain and maintain, for the duration of this Contract, the following insurance coverage:

- (a) Contractor's All Risk Insurance;
- (b) Transportation to the project Site of Equipment, Machinery, and Supplies owned by the Contractor;
- (c) Personal injury or death of Contractor's employees; and
- (d) Comprehensive insurance for third party liability to Contractor's direct or indirect act or omission causing damage to third persons.

14.2. The Contractor shall provide evidence to NPC's Representative that the insurances required under this Contract have been effected and shall, within a reasonable time, provide copies of the insurance policies to NPC's Representative. Such evidence and such policies shall be provided to NPC's through NPC's Representative.

14.3. The Contractor shall notify the insurers of changes in the nature, extent, or program for the execution of the Works and ensure the adequacy of the insurances at all times in accordance with the terms of this Contract and shall produce to NPC's Representative the insurance policies in force including the receipts for payment of the current premiums.

The above insurance policies shall be obtained from any reputable insurance company approved by NPC's Representative.

- 14.4. If the Contractor fails to obtain and keep in force the insurances referred to herein or any other insurance which he may be required to obtain under the terms of this Contract, NPC may obtain and keep in force any such insurances and pay such premiums as may be necessary for the purpose. From time to time, NPC may deduct the amount it shall pay for said premiums including twenty five percent (25%) therein from any monies due, or which may become due, to the Contractor, without prejudice to NPC exercising its right to impose other sanctions against the Contractor pursuant to the provisions of this Contract.
- 14.5. In the event the Contractor fails to observe the above safeguards, NPC may, at the Contractor's expense, take whatever measure is deemed necessary for its protection and that of the Contractor's personnel and third parties, and/or order the interruption of dangerous Works. In addition, NPC may refuse to make the payments under **GCC** Clause 38 until the Contractor complies with this Clause.
- 14.6. The Contractor shall immediately replace the insurance policy obtained as required in this Contract, without need of NPC's demand, with a new policy issued by a new insurance company acceptable to NPC for any of the following grounds:
- (a) The issuer of the insurance policy to be replaced has:
    - (i) become bankrupt;
    - (ii) been placed under receivership or under a management committee;
    - (iii) been sued for suspension of payment; or
    - (iv) been suspended by the Insurance Commission and its license to engage in business or its authority to issue insurance policies cancelled; or
    - (v) Where reasonable grounds exist that the insurer may not be able, fully and promptly, to fulfill its obligation under the insurance policy.

## 15. Termination for Default of Contractor

- 15.1. NPC shall terminate this Contract for default when any of the following conditions attend its implementation:
- (i) Due to the Contractor's fault and while the project is on-going, it has incurred negative slippage of fifteen percent (15%) or more in accordance with Presidential Decree 1870, regardless of whether or not previous warnings and notices have been issued for the Contractor to improve his performance;
  - (ii) Due to its own fault and after this Contract time has expired, the Contractor incurs delay in the completion of the Work after this Contract has expired; or
  - (iii) The Contractor:

- (i) abandons the contract Works, refuses or fails to comply with a valid instruction of NPC or fails to proceed expeditiously and without delay despite a written notice by NPC;
- (ii) does not actually have on the project Site the minimum essential equipment listed on the bid necessary to prosecute the Works in accordance with the approved Program of Work and equipment deployment schedule as required for the project;
- (iii) does not execute the Works in accordance with this Contract or persistently or flagrantly neglects to carry out its obligations under this Contract;
- (iv) neglects or refuses to remove materials or to perform a new Work that has been rejected as defective or unsuitable; or
- (v) sub-lets any part of this Contract without approval by NPC.

15.2. All materials on the Site, Plant, Works, including Equipment purchased and funded under the Contract shall be deemed to be the property of NPC if this Contract is rescinded because of the Contractor's default.

#### **16. Termination for Default of NPC**

The Contractor may terminate this Contract with NPC if the works are completely stopped for a continuous period of at least sixty (60) calendar days through no fault of its own, due to any of the following reasons:

- (a) Failure of NPC to deliver, within a reasonable time, supplies, materials, right-of-way, or other items it is obligated to furnish under the terms of this Contract; or
- (b) The prosecution of the Work is disrupted by the adverse peace and order situation, as certified by the Armed Forces of the Philippines Provincial Commander and approved by the Secretary of National Defense.

#### **17. Termination for Other Causes**

17.1. NPC may terminate this Contract, in whole or in part, at any time for its convenience. The Head of NPC may terminate this Contract for the convenience of NPC if he has determined the existence of conditions that make Project Implementation economically, financially or technically impractical and/or unnecessary, such as, but not limited to, fortuitous event(s) or changes in law and National Government policies.

17.2. NPC or the Contractor may terminate this Contract if the other party causes a fundamental breach of this Contract.

17.3. Fundamental breaches of Contract shall include, but shall not be limited to, the following:

- (a) The Contractor stops work for twenty eight (28) days when no stoppage of work is shown on the current Program of Work and the stoppage has not been authorized by NPC's Representative;

- (b) NPC's Representative instructs the Contractor to delay the progress of the Works, and the instruction is not withdrawn within twenty eight (28) days;
  - (c) NPC shall terminate this Contract if the Contractor is declared bankrupt or insolvent as determined with finality by a court of competent jurisdiction. In this event, termination will be without compensation to the Contractor, provided that such termination will not prejudice or affect any right of action or remedy which has accrued or will accrue thereafter to NPC and/or the Contractor. In the case of the Contractor's insolvency, any Contractor's Equipment which NPC instructs in the notice is to be used until the completion of the Works;
  - (d) A payment certified by NPC's Representative is not paid by NPC to the Contractor within eighty four (84) days from the date of NPC's Representative's certificate;
  - (e) NPC's Representative gives Notice that failure to correct a particular Defect is a fundamental breach of Contract and the Contractor fails to correct it within a reasonable period of time determined by NPC's Representative;
  - (f) The Contractor does not maintain a Security, which is required;
  - (g) The Contractor has delayed the completion of the Works by the number of days for which the maximum amount of liquidated damages can be paid, as defined in the **GCC** Clause 9; and
  - (h) In case it is determined prima facie by NPC that the Contractor has engaged, before or during the implementation of the contract, in unlawful deeds and behaviors relative to contract acquisition and implementation, such as, but not limited to, the following:
    - (i) corrupt, fraudulent, collusive, coercive, and obstructive practices as defined in **ITB** Clause 3.1(a);
    - (ii) drawing up or using forged documents;
    - (iii) using adulterated materials, means or methods, or engaging in production contrary to rules of science or the trade; and
    - (iv) any other act analogous to the foregoing.
- 17.4. The Funding Source or NPC, as appropriate, will seek to impose the maximum civil, administrative and/or criminal penalties available under the applicable law on individuals and organizations deemed to be involved with corrupt, fraudulent, or coercive practices.
- 17.5. When persons from either party to this Contract gives notice of a fundamental breach to NPC's Representative in order to terminate the existing contract for a cause other than those listed under **GCC** Clause 17.3, NPC's Representative shall decide whether the breach is fundamental or not.
- 17.6. If this Contract is terminated, the Contractor shall stop work immediately, make the Site safe and secure, and leave the Site as soon as reasonably possible.



**18. Procedures for Termination of Contracts**

18.1. The following provisions shall govern the procedures for the termination of this Contract:

- (a) Upon receipt of a written report of acts or causes which may constitute ground(s) for termination as aforementioned, or upon its own initiative, NPC shall, within a period of seven (7) calendar days, verify the existence of such ground(s) and cause the execution of a Verified Report, with all relevant evidence attached;
- (b) Upon recommendation by Head of NPC, NPC shall terminate this Contract only by a written notice to the Contractor conveying the termination of this Contract. The notice shall state:
  - (i) that this Contract is being terminated for any of the ground(s) afore-mentioned, and a statement of the acts that constitute the ground(s) constituting the same;
  - (ii) the extent of termination, whether in whole or in part;
  - (iii) an instruction to the Contractor to show cause as to why this Contract should not be terminated; and
  - (iv) special instructions of NPC, if any.

The Notice to Terminate shall be accompanied by a copy of the Verified Report;

- (c) Within a period of seven (7) calendar days from receipt of the Notice of Termination, the Contractor shall submit to the Head of NPC a verified position paper stating why the contract should not be terminated. If the Contractor fails to show cause after the lapse of the seven (7) day period, either by inaction or by default, the Head of NPC shall issue an order terminating the contract;
- (d) NPC may, at anytime before receipt of the Contractor's verified position paper described in item (c) above withdraw the Notice to Terminate if it is determined that certain items or works subject of the notice had been completed, delivered, or performed before the Contractor's receipt of the notice;
- (e) Within a non-extendible period of ten (10) calendar days from receipt of the verified position paper, the Head of NPC shall decide whether or not to terminate this Contract. It shall serve a written notice to the Contractor of its decision and, unless otherwise provided in the said notice, this Contract is deemed terminated from receipt of the Contractor of the notice of decision. The termination shall only be based on the ground(s) stated in the Notice to Terminate; and
- (f) The Head of NPC may create a Contract Termination Review Committee (CTRC) to assist him in the discharge of this function. All decisions recommended by the CTRC shall be subject to the approval of the Head of NPC.

## SECTION II – GENERAL CONDITIONS OF CONTRACT

- 18.2. Pursuant to Section 69(f) of RA 9184 and without prejudice to the imposition of additional administrative sanctions as the internal rules of the agency may provide and/or further criminal prosecution as provided by applicable laws, NPC shall impose on contractors after the termination of the contract the penalty of suspension for one (1) year for the first offense, suspension for two (2) years for the second offense from participating in the public bidding process, for violations committed during the contract implementation stage, which include but not limited to the following:
- (a) Failure of the contractor, due solely to his fault or negligence, to mobilize and start work or performance within the specified period in the Notice to Proceed ("NTP");
  - (b) Failure by the contractor to fully and faithfully comply with its contractual obligations without valid cause, or failure by the contractor to comply with any written lawful instruction of NPC or its representative(s) pursuant to the implementation of the contract. For the procurement of infrastructure projects or consultancy contracts, lawful instructions include but are not limited to the following:
    - (i) Employment of competent technical personnel, competent engineers and/or work supervisors;
    - (ii) Provision of warning signs and barricades in accordance with approved plans and specifications and contract provisions;
    - (iii) Stockpiling in proper places of all materials and removal from the project site of waste and excess materials, including broken pavement and excavated debris in accordance with approved plans and specifications and contract provisions;
    - (iv) Deployment of committed equipment, facilities, support staff and manpower; and
    - (v) Renewal of the effectivity dates of the performance security after its expiration during the course of contract implementation.
  - (c) Assignment and subcontracting of the contract or any part thereof or substitution of key personnel named in the proposal without prior written approval by NPC.
  - (d) Poor performance by the contractor or unsatisfactory quality and/or progress of work arising from his fault or negligence as reflected in the Constructor's Performance Evaluation System ("CPES") rating sheet. In the absence of the CPES rating sheet, the existing performance monitoring system of NPC shall be applied. Any of the following acts by the Contractor shall be construed as poor performance:
    - (i) Negative slippage of 15% and above within the critical path of the project due entirely to the fault or negligence of the contractor; and
    - (ii) Quality of materials and workmanship not complying with the approved specifications arising from the contractor's fault or negligence.

- (e) Willful or deliberate abandonment or non-performance of the project or contract by the contractor resulting to substantial breach thereof without lawful and/or just cause.

In addition to the penalty of suspension, the performance security posted by the contractor shall also be forfeited.

## 19. Force Majeure, Release From Performance

- 19.1. For purposes of this Contract the terms "*force majeure*" and "fortuitous event" may be used interchangeably. In this regard, a fortuitous event or *force majeure* shall be interpreted to mean an event which the Contractor could not have foreseen, or which though foreseen, was inevitable. It shall not include ordinary unfavorable weather conditions; and any other cause the effects of which could have been avoided with the exercise of reasonable diligence by the Contractor.
- 19.2. If this Contract is discontinued by an outbreak of war or by any other event entirely outside the control of either NPC or the Contractor, NPC's Representative shall certify that this Contract has been discontinued. The Contractor shall make the Site safe and stop work as quickly as possible after receiving this certificate and shall be paid for all works carried out before receiving it and for any Work carried out afterwards to which a commitment was made.
- 19.3. If the event continues for a period of eighty four (84) days, either party may then give notice of termination, which shall take effect twenty eight (28) days after the giving of the notice.
- 19.4. After termination, the Contractor shall be entitled to payment of the unpaid balance of the value of the Works executed and of the materials and Plant reasonably delivered to the Site, adjusted by the following:
- (a) any sum to which the Contractor is entitled under **GCC** Clause 27;
  - (b) the cost of his suspension and demobilization;
  - (c) any sum to which NPC is entitled.
- 19.5. The net balance due shall be paid or repaid within a reasonable time period from the time of the notice of termination.

## 20. Resolution of Disputes

- 20.1. If any dispute or difference of any kind whatsoever shall arise between the parties in connection with the implementation of the contract covered by the Act and this IRR, the parties shall make every effort to resolve amicably such dispute or difference by mutual consultation.
- 20.2. If the Contractor believes that a decision taken by NPC's Representative was either outside the authority given to NPC's Representative by this Contract or that the decision was wrongly taken, the decision shall be referred to the Construction Industry Arbitration Commission (CIAC) - Construction Industry Authority of the Philippines (CIAP), within fourteen (14) days of the notification of NPC's Representative's decision.

20.3. Any and all disputes arising from the implementation of this Contract covered by the R.A. 9184 and its IRR shall be submitted to arbitration in the Philippines according to the provisions of Republic Act No. 876, otherwise known as the "Arbitration Law" and Republic Act 9285, otherwise known as the "Alternative Dispute Resolution Act of 2004": *Provided, however,* That, disputes that are within the competence of the Construction Industry Arbitration Commission to resolve shall be referred thereto. The process of arbitration shall be incorporated as a provision in this Contract that will be executed pursuant to the provisions of the Act and its IRR: *Provided, further,* That, by mutual agreement, the parties may agree in writing to resort to other alternative modes of dispute resolution.

## **21. Suspension of Loan, Credit, Grant, or Appropriation**

In the event that the Funding Source suspends the Loan, Credit, Grant, or Appropriation to NPC, from which part of the payments to the Contractor are being made:

- (a) NPC is obligated to notify the Contractor of such suspension within seven (7) days of having received the suspension notice.
- (b) If the Contractor has not received sums due it for work already done within forty five (45) days from the time the Contractor's claim for payment has been certified by NPC's Representative, the Contractor may immediately issue a suspension of work notice in accordance with **GCC** Clause 43.2.

## **22. NPC's Representative's Decisions**

- 22.1. Except where otherwise specifically stated, NPC's Representative will decide contractual matters between NPC and the Contractor in the role representing NPC.
- 22.2. NPC's Representative may delegate any of his duties and responsibilities to other people, except to the Arbitrator, after notifying the Contractor, and may cancel any delegation after notifying the Contractor.

## **23. Approval of Drawings and Temporary Works by NPC's Representative**

- 23.1. All Drawings prepared by the Contractor for the execution of the Temporary Works, are subject to prior approval by NPC's Representative before its use.
- 23.2. The Contractor shall be responsible for design of Temporary Works.
- 23.3. NPC's Representative's approval shall not alter the Contractor's responsibility for design of the Temporary Works.
- 23.4. The Contractor shall obtain approval of third parties to the design of the Temporary Works, when required by NPC.

## **24. Acceleration and Delays Ordered by NPC's Representative**

- 24.1. When NPC wants the Contractor to finish before the Intended Completion Date, NPC's Representative will obtain priced proposals for achieving the necessary acceleration from the Contractor. If NPC accepts these proposals, the Intended Completion Date will be adjusted accordingly and confirmed by both NPC and the Contractor.

- 24.2. If the Contractor's Financial Proposals for an acceleration are accepted by NPC, they are incorporated in the Contract Price and treated as a Variation.

**25. Extension of the Intended Completion Date**

- 25.1. NPC's Representative shall extend the Intended Completion Date if a Variation is issued which makes it impossible for the Intended Completion Date to be achieved by the Contractor without taking steps to accelerate the remaining work, which would cause the Contractor to incur additional costs. No payment shall be made for any event which may warrant the extension of the Intended Completion Date.
- 25.2. NPC's Representative shall decide whether and by how much to extend the Intended Completion Date within twenty one (21) days of the Contractor asking NPC's Representative for a decision thereto after fully submitting all supporting information. If the Contractor has failed to give early warning of a delay or has failed to cooperate in dealing with a delay, the delay by this failure shall not be considered in assessing the new Intended Completion Date.

**26. Right to Vary**

- 26.1. NPC's Representative with the prior approval of NPC may instruct Variations, up to a maximum cumulative amount of ten percent (10%) of the original contract cost.
- 26.2. Variations shall be valued as follows:
- (a) At a lump sum price agreed between the parties;
  - (b) where appropriate, at rates in this Contract;
  - (c) in the absence of appropriate rates, the rates in this Contract shall be used as the basis for valuation; or failing which
  - (d) at appropriate new rates, equal to or lower than current industry rates and to be agreed upon by both parties and approved by the Head of NPC.

**27. Contractor's Right to Claim**

If the Contractor incurs cost as a result of any of the events under GCC Clause 12, the Contractor shall be entitled to the amount of such cost. If as a result of any of the said events, it is necessary to change the Works, this shall be dealt with as a Variation.

**28. Early Warning**

- 28.1. The Contractor shall warn NPC's Representative at the earliest opportunity of specific likely future events or circumstances that may adversely affect the quality of the work, increase the Contract Price, or delay the execution of the Works. NPC's Representative may require the Contractor to provide an estimate of the expected effect of the future event or circumstance on the Contract Price and Completion Date. The estimate shall be provided by the Contractor as soon as reasonably possible.

- 28.2. The Contractor shall cooperate with NPC's Representative in making and considering proposals for how the effect of such an event or circumstance can be avoided or reduced by anyone involved in the work and in carrying out any resulting instruction of NPC's Representative.

## 29. Program of Work

- 29.1. Within Ten (10) calendar days from receipt of the Notice of Award/Letter of Acceptance, the Contractor shall submit to NPC's Representative for approval a Program of Work showing the general methods, arrangements, order, and timing for all the activities in the Works.
- 29.2. An update of the Program of Work shall show the actual progress achieved on each activity and the effect of the progress achieved on the timing of the remaining work, including any changes to the sequence of the activities.
- 29.3. The Contractor shall submit to NPC's Representative for approval an updated Program of Work at intervals no longer than Thirty (30) Calendar Days. If the Contractor does not submit an updated Program of Work within this period, NPC's Representative may withhold One Percent (1%) of contract amount from the next payment certificate and continue to withhold this amount until the next payment after the date on which the overdue Program of Work has been submitted.
- 29.4. NPC's Representative's approval of the Program of Work shall not alter the Contractor's obligations. The Contractor may revise the Program of Work and submit it to NPC's Representative again at any time. A revised Program of Work shall show the effect of any approved Variations.
- 29.5. When the Program of Work is updated, the Contractor shall provide NPC's Representative with an updated cash flow forecast. The cash flow forecast shall include different currencies, as defined in the Contract, converted as necessary using the Contract exchange rates.
- 29.6. All Variations shall be included in updated Program of Work produced by the Contractor.

## 30. Management Conferences

- 30.1. Either NPC's Representative or the Contractor may require the other to attend a Management Conference. The Management Conference shall review the plans for remaining work and deal with matters raised in accordance with the early warning procedure.
- 30.2. NPC's Representative shall record the business of Management Conferences and provide copies of the record to those attending the Conference and to NPC. The responsibility of the parties for actions to be taken shall be decided by NPC's Representative either at the Management Conference or after the Management Conference and stated in writing to all who attended the Conference.

## 31. Bill of Quantities

- 31.1. The Bill of Quantities shall contain items of work for the construction, installation, testing, and commissioning of work to be done by the Contractor.

- 31.2. The Bill of Quantities is used to calculate the Contract Price. The Contractor is paid for the quantity of the work done at the rate in the Bill of Quantities for each item.
- 31.3. If the final quantity of any work done differs from the quantity in the Bill of Quantities for the particular item and is not more than twenty five percent (25%) of the original quantity, provided the aggregate changes for all items do not exceed ten percent (10%) of the Contract price, NPC's Representative shall make the necessary adjustments to allow for the changes subject to applicable laws, rules, and regulations.
- 31.4. If requested by NPC's Representative, the Contractor shall provide NPC's Representative with a detailed cost breakdown of any rate in the Bill of Quantities.

## **32. Instructions, Inspections and Audits**

- 32.1. NPC's personnel shall at all reasonable times during construction of the Work be entitled to examine, inspect, measure and test the materials and workmanship, and to check the progress of the construction.
- 32.2. If NPC's Representative instructs the Contractor to carry out a test not specified in the Specification to check whether any work has a defect and the test shows that it does, the Contractor shall pay for the test and any samples. If there is no defect, the test shall be a Compensation Event.
- 32.3. The Contractor shall permit NPC to inspect the Contractor's accounts and records relating to the performance of the Contractor and to have them audited by auditors appointed by NPC, if so required by NPC.
- 32.4. During contract implementation, NPC shall conduct Constructors Performance Evaluation in accordance with Section 12, Annex E of the Revised Implementing Rules and Regulation of R.A. 9184 using the NPC Constructors Performance Evaluation System (CPES) Guidelines.

CPES ratings shall be used for the following purposes: a) eligibility screening/post-qualification; b) awarding of contracts; c) project monitoring & control; d) issuance of Certificate of Completion; and in adopting measures to further improve performance of contractors in the prosecution of government projects.

Qualified Constructors Performance Evaluators (CPE) shall conduct project evaluation as follows:

- (a) During Construction - Except for those projects with a duration of 90 calendar days and below which may be subjected to at least one (1) visit, all projects shall be subjected to a minimum of two (2) evaluations to be performed by the CPE. The number of evaluations beyond the prescribed minimum shall be determined by the CPES-Implementing Unit based on the size, nature and complexity of the project and shall be subject to approval by the proper authorities within the agency. The first evaluation shall be performed when the project is at least thirty percent (30%) physically complete or as maybe required by the CPES-IU using the S-curve or other appropriate means to determine whether there is substantial work completed for evaluation.

- (b) Upon Completion - only one evaluation shall be performed by the CPE right after the Project Implementation Group reports one hundred percent (100%) completion of the project.

### **33. Identifying Defects**

NPC's Representative shall check the Contractor's work and notify the Contractor of any defects that are found. Such checking shall not affect the Contractor's responsibilities. NPC's Representative may instruct the Contractor to search uncover defects and test any work that NPC's Representative considers below standards and defective.

### **34. Cost of Repairs**

Loss or damage to the Works or Materials to be incorporated in the Works between the Start Date and the end of the Defects Liability Periods shall be remedied by the Contractor at the Contractor's cost if the loss or damage arises from the Contractor's acts or omissions.

### **35. Correction of Defects**

- 35.1. NPC's Representative shall give notice to the Contractor of any defects before the end of the Defects Liability Period, which is One (1) year from project completion up to final acceptance by NPC's Representative.
- 35.2. Every time notice of a defect is given, the Contractor shall correct the notified defect within the length of time specified in NPC's Representative's notice.
- 35.3. The Contractor shall correct the defects which he notices himself before the end of the Defects Liability Period.
- 35.4. NPC shall certify that all defects have been corrected. If NPC considers that correction of a defect is not essential, he can request the Contractor to submit a quotation for the corresponding reduction in the Contract Price. If NPC accepts the quotation, the corresponding change in the SCC is a Variation.

### **36. Uncorrected Defects**

- 36.1. NPC shall give the Contractor at least fourteen (14) days notice of his intention to use a third party to correct a Defect. If the Contractor does not correct the Defect himself within the period, NPC may have the Defect corrected by the third party. The cost of the correction will be deducted from the Contract Price.
- 36.2. The use of a third party to correct defects that are uncorrected by the Contractor will in no way relieve the Contractor of its liabilities and warranties under the Contract.

### **37. Advance Payment**

- 37.1. NPC shall, upon a written request of the contractor which shall be submitted as a contract document, make an advance payment to the contractor in an amount not exceeding fifteen percent (15%) of the total contract price, to be made in lump sum.
- 37.2. The advance payment shall be made only upon the submission to and acceptance by NPC of an irrevocable standby letter of credit of equivalent value



from a commercial bank, a bank guarantee or a surety bond callable upon demand, issued by a surety or insurance company duly licensed by the Insurance Commission and confirmed by NPC.

- 37.3. The advance payment shall be repaid by the Contractor by an amount equal to the percentage of the total contract price used for the advance payment.
- 37.4. The contractor may reduce his standby letter of credit or guarantee instrument by the amounts refunded by the Monthly Certificates in the advance payment.
- 37.5. NPC will provide an Advance Payment on the Contract Price as stipulated in the Conditions of Contract, subject to the maximum amount stated in **GCC** Clause 37.1.

### **38. Progress Payments**

- 38.1. The Contractor may submit a request for payment for Work accomplished. Such request for payment shall be verified and certified by NPC's Representative/Project Engineer. Materials and equipment delivered on the site but not completely put in place shall not be included for payment.
- 38.2. NPC shall deduct the following from the certified gross amounts to be paid to the contractor as progress payment:
  - (a) Cumulative value of the work previously certified and paid for.
  - (b) Portion of the advance payment to be recouped for the month.
  - (c) Retention money in accordance with the condition of contract.
  - (d) Amount to cover third party liabilities.
  - (e) Amount to cover uncorrected discovered defects in the works.
- 38.3. Payments shall be adjusted by deducting therefrom the amounts for advance payments and retention. NPC shall pay the Contractor the amounts certified by NPC's Representative within twenty eight (28) days from the date each certificate was issued. No payment of interest for delayed payments and adjustments shall be made by NPC.
- 38.4. The first progress payment may be paid by NPC to the Contractor provided that at least twenty percent (20%) of the work has been accomplished as certified by NPC's Representative.
- 38.5. Items of the Works for which a price of "0" (zero) has been entered will not be paid for by NPC and shall be deemed covered by other rates and prices in the Contract.

### **39. Payment Certificates**

- 39.1. The Contractor shall submit to NPC's Representative monthly statements of the estimated value of the work executed less the cumulative amount certified previously.
- 39.2. NPC's Representative shall check the Contractor's monthly statement and certify the amount to be paid to the Contractor.

- 39.3. The value of Work executed shall:
- (a) be determined by NPC's Representative;
  - (b) comprise the value of the quantities of the items in the Bill of Quantities completed; and
  - (c) include the valuations of approved variations.
- 39.4. NPC's Representative may exclude any item certified in a previous certificate or reduce the proportion of any item previously certified in any certificate in the light of later information.

#### 40. Retention

- 40.1. NPC shall retain from each payment due to the Contractor an amount equal to a percentage thereof using the rate as specified in GCC Sub-Clause 40.2.
- 40.2. Progress payments are subject to retention of ten percent (10%), referred to as the "retention money." Such retention shall be based on the total amount due to the Contractor prior to any deduction and shall be retained from every progress payment until fifty percent (50%) of the value of Works, as determined by NPC, are completed. If, after fifty percent (50%) completion, the Work is satisfactorily done and on schedule, no additional retention shall be made; otherwise, the ten percent (10%) retention shall again be imposed using the rate specified therefor.
- 40.3. The total "retention money" shall be due for release upon final acceptance of the Works. The Contractor may, however, request the substitution of the retention money for each progress billing with irrevocable standby letters of credit from a commercial bank, bank guarantees or surety bonds callable on demand, of amounts equivalent to the retention money substituted for and acceptable to NPC, provided that the project is on schedule and is satisfactorily undertaken. Otherwise, the ten (10%) percent retention shall be made. Said irrevocable standby letters of credit, bank guarantees and/or surety bonds, to be posted in favor of the Government shall be valid for a duration to be determined by the concerned implementing office/agency or NPC and will answer for the purpose for which the ten (10%) percent retention is intended, *i.e.*, to cover uncorrected discovered defects and third party liabilities.
- 40.4. On completion of the whole Works, the Contractor may substitute retention money with an "on demand" Bank guarantee in a form acceptable to NPC.

#### 41. Variation Orders

- 41.1. Variation Orders may be issued by NPC to cover any increase/decrease in quantities, including the introduction of new work items that are not included in the original contract or reclassification of work items that are either due to change of plans, design or alignment to suit actual field conditions resulting in disparity between the preconstruction plans used for purposes of bidding and the "as staked plans" or construction drawings prepared after a joint survey by the Contractor and NPC after award of the contract, provided that the cumulative amount of the Variation Order does not exceed ten percent (10%) of the original project cost. The addition/deletion of Works should be within the general scope of the project as bid and awarded. The scope of works shall not

- be reduced so as to accommodate a positive Variation Order. A Variation Order may either be in the form of a Change Order or Extra Work Order.
- 41.2. A Change Order may be issued by NPC to cover any increase/decrease in quantities of original Work items in the contract.
- 41.3. An Extra Work Order may be issued by NPC to cover the introduction of new work necessary for the completion, improvement or protection of the project which were not included as items of Work in the original contract, such as, where there are subsurface or latent physical conditions at the site differing materially from those indicated in the contract, or where there are duly unknown physical conditions at the site of an unusual nature differing materially from those ordinarily encountered and generally recognized as inherent in the Work or character provided for in the contract.
- 41.4. Any cumulative Variation Order beyond ten percent (10%) shall be subject of another contract to be bid out if the works are separable from the original contract. In exceptional cases where it is urgently necessary to complete the original scope of work, the Head of NPC may authorize a positive Variation Order go beyond ten percent (10%) but not more than twenty percent (20%) of the original contract price, subject to the guidelines to be determined by the GPPB: *Provided, however,* That appropriate sanctions shall be imposed on the designer, consultant or official responsible for the original detailed engineering design which failed to consider the Variation Order beyond ten percent (10%).
- 41.5. In claiming for any Variation Order, the Contractor shall, within seven (7) calendar days after such work has been commenced or after the circumstances leading to such condition(s) leading to the extra cost, and within twenty-eight (28) calendar days deliver a written communication giving full and detailed particulars of any extra cost in order that it may be investigated at that time. Failure to provide either of such notices in the time stipulated shall constitute a waiver by the contractor for any claim. The preparation and submission of Variation Orders are as follows:
- (a) If NPC's representative/Project Engineer believes that a Change Order or Extra Work Order should be issued, he shall prepare the proposed Order accompanied with the notices submitted by the Contractor, the plans therefore, his computations as to the quantities of the additional works involved per item indicating the specific stations where such works are needed, the date of his inspections and investigations thereon, and the log book thereof, and a detailed estimate of the unit cost of such items of work, together with his justifications for the need of such Change Order or Extra Work Order, and shall submit the same to the Head of NPC for approval.
  - (b) The Head of NPC or his duly authorized representative, upon receipt of the proposed Change Order or Extra Work Order shall immediately instruct the appropriate technical staff or office of NPC to conduct an on-the-spot investigation to verify the need for the Work to be prosecuted and to review the proposed plan, and prices of the work involved.
  - (c) The technical staff or appropriate office of NPC shall submit a report of their findings and recommendations, together with the supporting

documents, to the Head of NPC or his duly authorized representative for consideration.

- (d) The Head of NPC or his duly authorized representative, acting upon the recommendation of the technical staff or appropriate office, shall approve the Change Order or Extra Work Order after being satisfied that the same is justified, necessary, and in order.
- (e) The timeframe for the processing of Variation Orders from the preparation up to the approval by NPC concerned shall not exceed thirty (30) calendar days.

#### 42. Contract Completion

Once the project reaches an accomplishment of ninety five (95%) of the total contract amount, NPC may create an inspectorate team to make preliminary inspection and submit a punch-list to the Contractor in preparation for the final turnover of the project. Said punch-list will contain, among others, the remaining Works, Work deficiencies for necessary corrections, and the specific duration/time to fully complete the project considering the approved remaining contract time. This, however, shall not preclude the claim of NPC for liquidated damages.

#### 43. Suspension of Work

- 43.1. NPC shall have the authority to suspend the work wholly or partly by written order for such period as may be deemed necessary, due to *force majeure* or any fortuitous events or for failure on the part of the Contractor to correct bad conditions which are unsafe for workers or for the general public, to carry out valid orders given by NPC or to perform any provisions of the contract, or due to adjustment of plans to suit field conditions as found necessary during construction. The Contractor shall immediately comply with such order to suspend the work wholly or partly.
- 43.2. The Contractor or its duly authorized representative shall have the right to suspend work operation on any or all projects/activities along the critical path of activities after fifteen (15) calendar days from date of receipt of written notice from the Contractor to the district engineer/regional director/consultant or equivalent official, as the case may be, due to the following:
  - (a) There exist right-of-way problems which prohibit the Contractor from performing work in accordance with the approved construction schedule.
  - (b) Requisite construction plans which must be owner-furnished are not issued to the contractor precluding any work called for by such plans.
  - (c) Peace and order conditions make it extremely dangerous, if not possible, to work. However, this condition must be certified in writing by the Philippine National Police (PNP) station which has responsibility over the affected area and confirmed by the Department of Interior and Local Government (DILG) Regional Director.
  - (d) There is failure on the part of NPC to deliver government-furnished materials and equipment as stipulated in the contract.

- (e) Delay in the payment of Contractor's claim for progress billing beyond forty-five (45) calendar days from the time the Contractor's claim has been certified to by NPC's authorized representative that the documents are complete unless there are justifiable reasons thereof which shall be communicated in writing to the Contractor.

43.3. In case of total suspension, or suspension of activities along the critical path, which is not due to any fault of the Contractor, the elapsed time between the effectivity of the order suspending operation and the order to resume work shall be allowed the Contractor by adjusting the contract time accordingly.

#### **44. Payment on Termination**

- 44.1. If the Contract is terminated because of a fundamental breach of Contract by the Contractor, NPC's Representative shall issue a certificate for the value of the work done and Materials ordered less advance payments received up to the date of the issue of the certificate and less the percentage to apply to the value of the work not completed, as indicated in the SCC. Additional Liquidated Damages shall not apply. If the total amount due to NPC exceeds any payment due to the Contractor, the difference shall be a debt payable to NPC.
- 44.2. If the Contract is terminated for NPC's convenience or because of a fundamental breach of Contract by NPC, NPC's Representative shall issue a certificate for the value of the work done, Materials ordered, the reasonable cost of removal of Equipment, repatriation of the Contractor's personnel employed solely on the Works, and the Contractor's costs of protecting and securing the Works, and less advance payments received up to the date of the certificate.
- 44.3. The net balance due shall be paid or repaid within twenty eight (28) days from the notice of termination.
- 44.4. If the Contractor has terminated the Contract under GCC Clauses 16 or 17, NPC shall promptly return the Performance Security to the Contractor.

#### **45. Extension of Contract Time**

- 45.1. Should the amount of additional work of any kind or other special circumstances of any kind whatsoever occur such as to fairly entitle the contractor to an extension of contract time, NPC shall determine the amount of such extension; provided that NPC is not bound to take into account any claim for an extension of time unless the Contractor has, prior to the expiration of the contract time and within thirty (30) calendar days after such work has been commenced or after the circumstances leading to such claim have arisen, delivered to NPC notices in order that it could have investigated them at that time. Failure to provide such notice shall constitute a waiver by the Contractor of any claim. Upon receipt of full and detailed particulars, NPC shall examine the facts and extent of the delay and shall extend the contract time completing the contract work when, in NPC's opinion, the findings of facts justify an extension.
- 45.2. No extension of contract time shall be granted the Contractor due to (a) ordinary unfavorable weather conditions and (b) inexcusable failure or

negligence of Contractor to provide the required equipment, supplies or materials.

- 45.3. Extension of contract time may be granted only when the affected activities fall within the critical path of the PERT/CPM network.
- 45.4. No extension of contract time shall be granted when the reason given to support the request for extension was already considered in the determination of the original contract time during the conduct of detailed engineering and in the preparation of the contract documents as agreed upon by the parties before contract perfection.
- 45.5. Extension of contract time shall be granted for rainy/unworkable days considered unfavorable for the prosecution of the works at the site, based on the actual conditions obtained at the site, in excess of the number of rainy/unworkable days pre-determined by NPC in relation to the original contract time during the conduct of detailed engineering and in the preparation of the contract documents as agreed upon by the parties before contract perfection, and/or for equivalent period of delay due to major calamities such as exceptionally destructive typhoons, floods and earthquakes, and epidemics, and for causes such as non-delivery on time of materials, working drawings, or written information to be furnished by NPC, non-acquisition of permit to enter private properties or non-execution of deed of sale or donation within the right-of-way resulting in complete paralyzation of construction activities, and other meritorious causes as determined by NPC's Representative and approved by the Head of NPC. Shortage of construction materials, general labor strikes, and peace and order problems that disrupt construction operations through no fault of the Contractor may be considered as additional grounds for extension of contract time provided they are publicly felt and certified by appropriate government agencies such as DTI, DOLE, DILG, and DND, among others. The written consent of bondsmen must be attached to any request of the Contractor for extension of contract time and submitted to NPC for consideration and the validity of the Performance Security shall be correspondingly extended.

#### **46. Price Adjustment**

Except for extraordinary circumstances as determined by NEDA and approved by the GPPB, no price escalation shall be allowed. Nevertheless, in cases where the cost of the awarded contract is affected by any applicable new laws, ordinances, regulations, or other acts of the GoP, promulgated after the date of bid opening, a contract price adjustment shall be made or appropriate relief shall be applied on a no loss-no gain basis.

#### **47. Completion**

The Contractor shall request NPC's Representative to issue a certificate of Completion of the Works, and NPC's Representative will do so upon deciding that the work is completed.

#### **48. Taking Over**

NPC shall take over the Site and the Works within seven (7) days from the date NPC's Representative issues a certificate of Completion.

**49. Operating and Maintenance Manuals**

- 49.1. If "as built" Drawings and/or operating and maintenance manuals are required, the Contractor shall supply them within Thirty (30) Calendar Days after completion of contract.
- 49.2. If the Contractor does not supply the Drawings and/or manuals by the dates stated, or they do not receive NPC's Representative's approval, NPC's Representative shall withhold the Five Percent (5%) of contract amount from payments due to the Contractor.

SECTION III

**TECHNICAL SPECIFICATIONS**



SECTION III

**TECHNICAL SPECIFICATIONS**

***PROJECT HIGHLIGHTS***

## SECTION VI – TECHNICAL SPECIFICATIONS

### PROJECT HIGHLIGHTS

#### TABLE OF CONTENT

<u>CLAUSE NO.</u>	<u>TITLE</u>	<u>PAGE NO.</u>
<u>PH - 1.0</u>	<u>GENERAL</u> .....	<u>1</u>
<u>PH - 2.0</u>	<u>PROJECT LOCATION</u> .....	<u>1</u>
<u>PH - 3.0</u>	<u>SCOPE OF WORK</u> .....	<u>1</u>
<u>PH - 4.0</u>	<u>CONTRACT PERIOD</u> .....	<u>2</u>
<u>PH - 5.0</u>	<u>CONTRACTOR'S CLASSIFICATION</u> .....	<u>2</u>
<u>PH - 6.0</u>	<u>MINIMUM REQUIRED KEY PERSONNEL</u> .....	<u>2</u>
<u>PH - 7.0</u>	<u>MINIMUM REQUIRED CONSTRUCTION EQUIPMENT</u> .....	<u>2</u>

## PROJECT HIGHLIGHTS

### PH-1.0 GENERAL

The proposed breasting dolphins are essential to replace the damaged breasting dolphin during the recent storm surge in the area. Power Barge 120 was moored at Balanacan Pier to augment the power supply needed in the province of Marinduque.

### PH-2.0 PROJECT LOCATION

The project is located near the existing Balanacan Pier at Mogpog, Marinduque.

### PH-3.0 SCOPE OF WORK

The works and services to be performed by the Contractor for this undertaking shall essentially consist of, but not limited to the following:

- a. Mobilization/establishment of Contractor's complete construction camp and other facilities;
- b. Furnishing, delivery, driving, splicing and cutting of pre-stressed concrete piles for the additional breasting structures/dolphins;
- c. Concreting of concrete pile caps;
- d. Furnishing and installation of used rubber tire fenders;
- e. Demobilization including clearing of site/demolition of Contractor's camp facilities.

### PH-4.0 CONTRACT PERIOD

The contractor shall complete the works within Forty Five (45) calendar days. The total contract duration is inclusive of five (5) unworkable days considered unfavorable for the execution of work at site. The contract period shall be reckoned from the date of contract effectivity as specified in the Notice to Proceed.

### PH-5.0 CONTRACTOR'S CLASSIFICATION

The Contractor must have a valid Philippine Contractors Accreditation Board (PCAB) license of at least **Category D – General Engineering** and registration classification of at least **Small B – Port, Harbor or Offshore Engineering**.

The Contractor must have undertaken similar contracts and/or projects involving construction/rehabilitation of mooring facilities, piers, port terminal or loading/unloading jetty.

**PH-6.0 MINIMUM REQUIRED KEY PERSONNEL**

1. One (1) Project Engineer – Registered Civil Engineer who had supervised at least a project similar in nature as to the type and cost of the proposed project within the last ten (10) years. Must have at least 5 years professional experience as Civil Engineer on similar project.
2. One (1) Materials Engineer I – Registered Civil Engineer with valid accreditation from the Department of Public Works and Highways (DPWH) as Materials Engineer I.
3. One (1) Safety Officer 2 – Construction Safety Officer who has completed at least forty (40) hours of Construction Safety and Health Training (COSH) or Safety Training Organizations (STOs) accredited by the Department of Labor and Employment (DOLE).

Valid Professional Regulations Commission (PRC) license for professional personnel. Construction Safety and Health Training Certificate from OSCH/STOs accredited by DOLE for the Safety and Health Officer, certificate of accreditation including ID card issued by DPWH for Materials Engineer, shall be submitted and included as an attachment in the Standard Form NPCSF-INFR-09: List of Key Personnel Proposed to be Assigned to the Contract.

The above key personnel must either be employed by the Bidder or contracted by the Bidder to be employed for the contract to be bid.

**PH-7.0 MINIMUM REQUIRED CONSTRUCTION EQUIPMENT**

(Owned or Leased):

- |  |          |
|--|----------|
| a. Pile Driving Equipment (Barge Mounted)<br>complete with 4.5 ton ram weight, 25 ton drop<br>hammer and 40-50ton capacity crane | - 1 unit |
| b. Deck Barge (800 to 1000DWT)   | - 1 unit |
| c. Welding Machine (500 Amp).  | - 1 unit |
| d. Concrete Mixer (2-bagger)   | - 1 unit |
| e. Bar Cutter (32mm $\Phi$ capable)  | - 1 unit |
| f. Portable Generator  | - 1 unit |
| g. Oxy-acetylene Cutting Outfit  | - 1 unit |
| h. Concrete Vibrator   | - 1 unit |
| i. Cargo Truck   | - 1 unit |
| j. Service Vehicle   | - 1 unit |

SECTION III

**TECHNICAL SPECIFICATIONS**

***CIVIL WORKS***

**SECTION VI – TECHNICAL SPECIFICATIONS****CIVIL WORKS****TABLE OF CONTENTS**

<b><u>CLAUSE NO.</u></b>	<b><u>TITLE</u></b>	<b><u>PAGE NO.</u></b>
<b>CW - 1.0</b>	<b>GENERAL CONSTRUCTION FACILITIES.....</b>	<b>1</b>
CW -1.1.	Scope .....	1
CW -1.2.	Moving-In.....	1
CW -1.3.	Contractor's Camp Facilities .....	1
CW -1.4.	Water Supply .....	1
CW -1.5.	Sewerage Disposal and Sanitation.....	1
CW -1.6.	Fire Protection.....	2
CW -1.7.	Construction Power.....	2
CW -1.8.	Camp Security .....	2
CW -1.9.	Construction Material Storage.....	2
CW -1.10.	Removal of Camp and Construction Facilities .....	2
CW -1.11.	Measurement and Payment .....	3
<b>CW - 2.0</b>	<b>FALSEWORK AND FORMWORK.....</b>	<b>4</b>
CW -2.1.	Scope .....	4
CW -2.2.	Material Requirement.....	4
CW -2.3.	Construction Requirements.....	4
CW -2.4.	Measurement and Payment .....	6
<b>CW - 3.0</b>	<b>CONCRETE.....</b>	<b>7</b>
CW -3.1.	Scope .....	7
CW -3.2.	Class of Concrete .....	7
CW -3.3.	Materials .....	7
CW -3.4.	Storage of Materials.....	8
CW -3.5.	Concreting .....	9
CW -3.6.	Measurement and Payment .....	10
<b>CW - 4.0</b>	<b>REINFORCING BAR.....</b>	<b>11</b>
CW -4.1.	Description.....	11
CW -4.2.	Material Requirement.....	11
CW -4.3.	Construction Requirement.....	11
CW -4.4.	Measurement and Payment .....	14
<b>CW - 5.0</b>	<b>STRUCTURAL STEEL.....</b>	<b>16</b>
CW -5.1.	General.....	16
CW -5.2.	Materials .....	16
CW -5.3.	Execution .....	17

CW -5.4.	Measurement and Payment .....	19
<b>CW - 6.0</b>	<b>MISCELLANEOUS STEEL.....</b>	<b>20</b>
CW -6.1.	Scope .....	20
CW -6.2.	Shop Drawings.....	20
CW -6.3.	Materials .....	20
CW -6.4.	Workmanship.....	20
CW -6.5.	Measurement and Payment .....	21
<b>CW - 7.0</b>	<b>PRE-STRESSED CONCRETE PILES .....</b>	<b>22</b>
CW -7.1.	Scope .....	22
CW -7.2.	Material Requirements.....	22
CW -7.3.	Preparation for Driving .....	22
CW -7.4.	Test Piling.....	22
CW -7.5.	Pile Driving.....	23
CW -7.6.	Cutting of Piles.....	24
CW -7.7.	Pile Formula.....	24
CW -7.8.	Pile Records .....	24
CW -7.9.	Measurement and Payment .....	24
<b>CW - 8.0</b>	<b>FENDER SYSTEM .....</b>	<b>26</b>
CW -8.1.	General.....	26
CW -8.2.	Materials .....	26
CW -8.3.	Anchorage Fastening.....	26
CW -8.4.	Measurement and Payment .....	26

**SECTION VI – TECHNICAL SPECIFICATIONS****CIVIL WORKS****CW - 1.0 GENERAL CONSTRUCTION FACILITIES****CW -1.1. Scope**

This section covers the construction and/or maintenance of access roads, drainage systems and other appurtenant structures, moving-in of the Contractor's construction equipment, setting up of the Contractor's camp and the disposition of the Contractor's various facilities at the end of the Contract.

**CW -1.2. Moving-In**

The Contractor shall bring to the site all his necessary construction equipment and plant and install all stationary construction equipment and plant at location and in the manner approved by the NPC. The Contractor shall submit sufficient detailed plans showing the proposed location of such stationary equipment and plant and other pertinent data. No installation of such stationary equipment shall be undertaken unless the corresponding plans have been approved by the NPC.

**CW -1.3. Contractor's Camp Facilities**

The Contractor shall provide and grade his camp site, construct his camp, employee housing, warehouse, machine and repair shops, fuel storage tanks and provide such related facilities and sanitary conveniences that the Contractor deems necessary for maintaining health, peace and order in the camp and work areas. The areas that may be used by the Contractor within the plant site shall be designated by the NPC.

The Contractor shall provide, maintain and operate, under competent direction, such camps and facilities as are necessary for the housing, feeding and accommodation of his employees.

**CW -1.4. Water Supply**

The Contractor shall, at his own expense, be responsible for the supply, installation, operation and maintenance of a safe and adequate supply of drinking and domestic water. Whenever there is a possibility of contamination of the water supply for drinking and domestic purposes, chlorination or some other approved methods of sterilization shall be carried out. The installation and maintenance of these services shall be subject to the approval of the NPC.

**CW -1.5. Sewerage Disposal and Sanitation**

The Contractor shall, at his own expense, be responsible for the installation operation and maintenance of an adequate sewerage disposal and sanitation system and shall provide adequate toilet and wash-up facilities for his employees at his camp and in the areas where work is being carried out. The Contractor shall execute the work with due regard to adequate sanitary provisions and applicable codes and shall take all necessary steps to prevent the pollution of water in any spring, river, or other sources of water supply. All



toilets or wash-up facilities shall be subject to the prior and continuing approval of the NPC.

**CW -1.6. Fire Protection**

The Contractor shall observe all necessary precautions against fire, shall provide and maintain at his own expense, portable fire-fighting equipment he may deem necessary, and shall comply with all applicable laws of the Philippines relating thereto.

In the event of an uncontrollable fire occurring in the area of the Contractor's operation, the Contractor shall have to extinguish the fire immediately at his own expense, to the full extent of the manpower and equipment employed under the contract at the time of the fire.

The Contractor shall indemnify NPC against all liabilities, claims, damages and/or lawsuits arising thereto.

**CW -1.7. Construction Power**

The Contractor shall be responsible for providing his own electric power supply required for construction and erection/installation. If power is available from NPC and should the Contractor elect to utilize the NPC's power supply, he shall make an arrangement with NPC concerned group as to the billing rates and other requirements needed for direct connection to NPC.

**CW -1.8. Camp Security**

The Contractor shall provide his own security force to the extent that he deems necessary for maintaining peace and order in the camp and work areas and to safeguard materials and equipment. Nothing under the provisions of this paragraph shall relieve the Contractor from full responsibility for the maintenance of peace and order and protection of life and property in all areas where he operates.

**CW -1.9. Construction Material Storage**

The Contractor is required to put up warehouse(s) with capacities sufficient to store construction materials required in the work. The warehouse(s) shall be specifically for this contract, notwithstanding his other facilities in the site that may serve the purpose.

**CW -1.10. Removal of Camp and Construction Facilities**

After the completion of the work covered by the contract and prior to acceptance of the completed work, the entire camp facilities of the Contractor, including its water supply system, electric distribution system, quarters, warehouses, shops, dining halls, commissaries, temporary shed and other facilities therein shall be removed by the Contractor. The site shall be cleared and cleaned as directed by the NPC.

**CW -1.11. Measurement and Payment**

No separate measurement and payment will be made for the Contractor's Construction Facilities. The entire cost thereof shall be included in the various pay items in the Bill of Quantities.

**CW - 2.0 FALSEWORK AND FORMWORK****CW -2.1. Scope**

This work covers the supply, construction, erection and removal of falsework and formwork. Falsework shall provide the necessary rigidity, support the loads imposed and produce finished structure alignment, dimensions and grades indicated on the Drawings or as directed by NPC. Formwork shall be of sufficient strength with all necessary bracing, fasteners, etc. and in conformity with the specified requirements of applicable building code requirements for concrete framework, and National Structural Code of the Philippines.

**CW -2.2. Material Requirement**

Timber, lumber, steel pipes and plywood to be used for falsework and formwork shall be sound and shall comply with the requirements of these specifications. Use forms where a smooth form finish is required. Lumber shall be square-edged or tongue-and-groove boards, free or raised grain, knotholes and the other surface defects. Steel when used shall conform to the requirements of the ASTM A36. Steel form surfaces shall not contain irregularities, dents, or sags.

Forms shall be wood, plywood, or steel. Wood forms for surfaces exposed to view in the finished structure and requiring a smooth form finish, shall be plywood. For unexposed surfaces, undressed square-edge lumber may be used. Forms for surfaces requiring special finishes shall be plywood, or shall be lined with plywood, a non-absorptive, hard-pressed fiberboard, absorptive-type lining or other suitable material. Plywood, other than for lining, shall be concrete-form plywood free of raised grain, torn surfaces, worn edges, patches, or other surface defects, which would impair the texture of the concrete surface. Surfaces of steel forms shall be free from irregularities, dents, and sags.

**CW -2.3. Construction Requirements****CW-3.3.1 Falsework and Formwork Construction**

The materials used in the falsework shall be of the quantity and quality necessary to withstand the stresses imposed. The workmanship used in the falsework shall be of such quality that the falsework will support the loads imposed on it without excessive settlement.

Suitable jacks or wedges shall be used in connection with the falsework to set the forms to their required grade and to take up any excessive settlement in the falsework either before or during the placement of the concrete.

Should unanticipated events occur, including settlements that deviate more than  $\pm 20$  mm, which in the opinion of the Contractor would prevent obtaining a structure conforming to the requirements of the specification, the placement of the concrete shall be discontinued until corrective measures satisfactory to the NPC are provided. In the event satisfactory measures are not provided prior to initial set of the concrete in the affected area, the placing of concrete shall be discontinued at a location determined by NPC. All unacceptable concrete shall be removed.



Should unanticipated events occur, including settlements that deviate more than  $\pm 20$  mm, which in the opinion of the Contractor would cause non-conformity to the requirements of the specification, the placement of the concrete shall be discontinued until corrective measures satisfactory to the NPC are provided. In the event that corrective measures are not undertaken prior to initial set of the concrete in the affected area, the placing of concrete shall be discontinued at a location determined by NPC and all concrete already poured and placed shall be removed at the expense of the contractor.

Forms shall be mortar and watertight, true to the dimensions, lines and grades of the structure and with the sufficient strength, rigidity, shape and surface smoothness as to leave the finished works true to the dimensions shown on the drawings or required by NPC and with the surface finish as specified.

The inside surfaces of forms shall be cleaned of all dirt, mortar and foreign material. Forms, which will subsequently be removed, shall be thoroughly coated with a release agent or coating prior to its use. The release agent shall be commercial quality form oil or other approved coating which will permit the ready release of the forms and will not discolor the concrete.

Formwork for concrete placed underwater shall be watertight.

Forms shall be constructed so that the form surface of the concrete does not undulate excessively in any direction. Undulations exceeding either 2 mm or  $1/270$  of the center distance between studs, joints, form stiffeners, form fasteners, or wales will be considered to be excessive. Should any form of the forming system, even though previously approved for the use, produce a concrete surface with excessive undulations, its use shall be discontinued until modifications, satisfactory to NPC's Representative, have been made. Portions of concrete structures with surface undulations in excess of the limits herein stated may be rejected by the NPC.

Form fasteners consisting of forms bolts, clamps or other devices shall be used as necessary to prevent spreading of the forms during concrete placement. The use of ties consisting of twisted wire loops to hold the forms in position will not be permitted.

All formworks shall be provided with adequate clean-out openings to permit inspection and easy cleaning after all reinforcement has been placed. Where forms for continuous surfaces are placed in successive units, the forms shall be fitted over the completed surface to obtain accurate alignment of the surface and to prevent leakage of mortar. Panel forms shall be constructed so that they can be removed without damaging the concrete. All exposed joints, edges, and external corners shall be chamfered a minimum of 20 mm unless specified otherwise herein. Forms for heavy girders and similar members shall be constructed with a proper camber.

- **Coating:** Before placing the concrete, the contact surface of forms shall be coated with a non-staining mineral oil or suitable non-staining form coating compound or shall be given two coats of nitrocellulose lacquer, except as specified otherwise. Mineral oil shall not be used on forms for surfaces, which are to be painted. For surfaces not exposed to view in the finished structure, sheathing may be wetted thoroughly with clean water. All excess coating shall be removed by wiping with cloths. Reused forms shall have the contact surfaces cleaned thoroughly. Those that have previous coatings shall be

given an additional application of the same coating. Plaster waste molds shall be applied with two coats of the thin shellac or lacquer and coated with soft or thinned non-staining grease.

- **Tolerance and Variations:** The Contractor shall set and maintain concrete forms to ensure that, after removal of the forms and prior to patching and finishing, no portion of the concrete work will exceed any of the tolerances specified. Variations in floor levels shall be measured before removal of supporting shores. The Contractor shall be responsible for ensuring that tolerances specified shall not be exceeded. Except as otherwise specified herein, tolerances shall conform to ACI 347.

#### CW-3.3.2 Removal of Falsework and Formwork

Unless otherwise shown on the drawings or permitted by NPC, falsework supporting any span of structures shall not be released before fourteen (14) days after the last concrete has been placed on the span and adjacent adjoining span where falsework is to release.

Falsework supporting deck overhangs and deck slabs between girders shall not be released until seven (7) days after the deck concrete has been placed.

In addition to the above requirements, no falsework shall be released until the supported concrete has attained a compressive strength of at least eighty (80%) percent of the required 28-day strength.

Falsework and formwork shall not be removed without the permission of NPC, and such permission shall not relieve the Contractor of the responsibility for the safety of the work. Blocks and bracing shall be removed at the time the forms are removed and in no case shall any portion of the wood forms be left in the concrete.

Falsework removal for continuous structures shall be as directed by NPC or shall be temporarily supported such that the structure is gradually subjected to its working stresses. False work shall not be released in any span until the strength specified herein.

When concrete strength tests are used for removal of forms and supports, such removal shall be used as a minimum:

	Min. Time	Min.% Strength
Centering under girders and beams	14 days	80%
Sides of beams and all vertical surfaces	1 day	70%
Floor Slabs	14 days	80%

All debris and refuse resulting from work shall be removed and the site left in a neat and presentable condition.

#### CW -2.4. Measurement and Payment

No separate measurement for payment will be made for this item. The entire cost thereof shall be included in the various pay items in the Bill of Quantities.

**CW - 3.0 CONCRETE****CW -3.1. Scope**

In accordance with the specifications contained in this section, the Contractor shall furnish all materials, labor, equipment and tools and perform all concreting works in accordance with the drawings, or as otherwise directed.

**CW -3.2. Class of Concrete**

Class of concrete or strength shall be as indicated on the drawings. Unless specified, the compressive strength of concrete shall conform to the requirement indicated on the provision of NSCP for Concrete and/or shall not be less than 20.7 MPa.

**CW -3.3. Materials****CW-3.3.1 Cement**

Cement for concrete works shall be furnished by the Contractor and shall conform to the requirements of the latest edition of the Standard Specifications for Portland Cement (ASTMC150).

Unless otherwise specified, cement shall be ordinary Portland cement. Type I for general construction which concrete is not in contact with soils or ground water and Type II for concrete in contact with soil or ground water.

Changing of brand or type of cement within the same structure will not be permitted unless with prior permission and approval obtained from the NPC.

**CW-3.3.2 Water**

Water for use in concrete shall be subject to the approval of the NPC. It shall not be salty and shall be reasonably clear and free from oil, acid, injurious alkali or vegetable matter.

**CW-3.3.3 Fine Aggregates**

Fine aggregates shall conform to the requirements of the latest edition of ASTM C33 and shall consist of hard, tough, durable and uncoated particles. Fine aggregates shall generally be rounded or cubical and reasonably free from flat or elongated particles. A thin, flat and elongated particle is defined as a particle having a maximum dimension greater than 5 times its maximum dimension.

Fine aggregate shall be well graded from coarse to fine, and gradation shall conform to the following requirements:

<b><u>Sieve Designation U. S.</u></b> <b><u>(Standard Square Mesh)</u></b>	<b><u>Percentage by</u></b> <b><u>Weight Passing</u></b>
9.5 mm (3/8")	100
4.76 mm (No. 4)	95-100
1.19 mm (No. 16)	50-85
0.297 mm (No. 50)	10-30
0.149 mm (No. 100)	2-10

**CW3.3.4 Coarse Aggregates**

Coarse aggregates shall conform to the requirements of the latest edition of ASTM C33 and shall consist of hard, tough, durable and clean, uncoated particles. All foreign materials and dust shall be removed by processing. Coarse aggregates shall generally be rounded and reasonably free from thin, flat and elongated particles (as defined in CW-5.3.4 above) in all sizes.

Coarse aggregates shall be well graded from coarse to fine and gradation shall conform to the following requirements:

<b>Sieve Designation</b> <b><u>U.S. Std. Square Mesh</u></b>	<b>Size Group</b> <b>Cumulative Percentage by Weight Passing</b>		
	<b>19.1 mm</b> <b>(3/4") max.</b>	<b>38.1 mm</b> <b>(1-1/2") max.</b>	<b>76.2 mm</b> <b>(3") max.</b>
88.9 mm (3-1/2")	-	-	100
76.2 mm (3")	-	-	90-100
50.8 mm (2")	-	100	20-55
38.1 mm (1-1/2")	-	90-100	0-15
25.4 mm (1")	100	20-55	0-5
19.1 mm (3/4")	90-100	0-15	-
9.5 mm (3/8")	20-55	0-5	-
4.76 mm (No. 4)	0-15	-	-
2.38 mm (No. 8)	0-5	-	-
<b><u>General Use</u></b>	<b><u>Minimum General Aggregate Diameter</u></b>		
Massive Concrete	76.2 mm (3")		
Heavy walls and slabs (0.75 m thick or more)	76.2 mm (3")		
Walls, slabs, beams (0.30 m to 0.75 m thick)	38.1 mm (1 1/2")		
Thin walls, slabs, beam (Less than 0.30 m thickness)	19.1 mm (3/4")		

**CW -3.4. Storage of Materials****CW-3.4.1 Cement**

Cement shall be stored in a dry, weather-tight, and properly ventilated structure with adequate provisions for the prevention of absorption of moisture. All storage facilities shall be subject to the approval of the NPC and all cement shall be stored in such a manner and arrangement as to permit easy access for inspection and identification. Attention is directed to the requirement that delivery of cement to the site of work shall be so scheduled that no cement shall remain in storage longer than thirty (30) days after issue by the manufacturer. To preclude the undue aging of stored cement, the Contractor will not be permitted to use cement newly delivered to the job site whenever previously delivered cement is still available for use. Sacked cement shall not be stacked higher than fourteen sacks at any time during its storage.



**CW-3.4.2 Aggregates**

Fine and coarse aggregates shall be handled and stored separately in such a manner as to prevent the inclusion of foreign materials, segregation, or loss of fines.

**CW -3.5. Concreting****CW-3.5.1 General**

The written approval of the NPC shall be secured prior to any concreting work. All concrete shall be poured on the dry and cleaned surfaces.

**CW-3.5.2 Placing Reinforcement Embedded Items**

Before concrete placement/pouring, embedded reinforcing steel and other embedded items shall be in place in accordance with the construction drawings or as directed by the NPC. Placing of reinforcing steel shall be in accordance with the specifications specified under Reinforcing Bar.

**CW-3.5.3 Mixing Concrete**

Mixing of concrete shall conform to the requirements of ACI Code for Concrete Construction.

**CW-3.5.4 Placing Concrete**

Concrete shall be conveyed from mixers to the forms or to the place of deposit as rapidly as possible and by methods that will prevent segregation or loss of ingredients. There shall be no vertical drop greater than 1.5 meters except where suitable equipment like metal pipe or tremie is used. The pipe or tremie shall be kept full of concrete and its end shall be kept buried in the newly placed concrete. Chutes through which concrete is delivered to the structure in a thin, continuously exposed flow will not be permitted except for very limited or isolated sections of the work.

Earth surfaces, upon which concrete shall be placed, shall be cleaned, dry and thoroughly compacted before placing the concrete.

Rock surface, upon which concrete shall be placed, shall be thoroughly cleaned of loose or semi-detached or unsound rock particles. Before placing concrete, all surfaces shall be wetted thoroughly to keep them in a completely moist condition, after which leveling mortar of the same cement ratio as the concrete mix complete contact between concrete and the leveled surface.

**CW-3.5.5 Finishing Concrete**

After the concrete has been deposited, distributed and vibrated, the concrete shall be struck off and screened by mechanical means approved by the NPC. The finishing machine shall be of the screening and troweling type designed and operated both to strike off and to consolidate. Hand finishing may be employed when suitable finishing machines are not available. Finishing of concrete shall be done, as directed, to the satisfaction of the NPC.

All finished surfaces shall be tested with 3 meters straight edge and any variation of the surface from the desired crown or cross section shall be properly corrected.

#### CW-3.5.6 Removal of Forms

Forms shall be removed as soon as practicable in order to avoid delay in curing and to make possible earliest practicable repair of surface imperfections, but in no case shall they be removed without approval. Any needed repair or treatment shall be performed at once and shall be followed immediately by the specified curing. Forms shall be removed with care so as to avoid injury to the concrete and any concrete so damaged shall be repaired as directed.

#### CW-3.5.7 Curing and Protection

Concrete shall be cured for a period of not less than fourteen (14) consecutive days by keeping the surfaces of concrete continuously (not periodically) wet. Where tongue and groove forms were used and left in place of curing, they shall be kept wet at all times prevent opening at the joints and drying out of the concrete.

#### **CW -3.6. Measurement and Payment**

Measurement for payment for Concrete (except concrete which shall not be measured for separate payment) will be based on the volume of concrete placed and accepted within the neat lines of the structure as shown on the drawings or in accordance with the manner of measurement set forth in the various sections of the Technical Provisions. No deduction will be made for rounded or beveled edges or space occupied by the metal items 10 sq. cm. or less in cross section, embedded in concrete.

Payment will be made at the corresponding contract unit price for the various items of concrete shown in the Bill of Quantities. Payment shall cover all costs for furnishing all labor, materials, including equipment and tools required for concreting work. Payment shall also include care of water.

**CW - 4.0 REINFORCING BAR****CW -4.1. Description**

This work shall consist of furnishing, fabricating, and placing of steel reinforcement of the type, size, shape and grade required in accordance with these specifications and in conformity with the requirements shown on the Drawings or as directed by the NPC.

**CW -4.2. Material Requirement**

All material shall conform to the requirements hereinafter given. Certified test reports (mill test or other) shall be submitted to the NPC for all reinforcement steel used. These tests shall show the results of all chemical and physical tests made.

**CW-4.2.1 Bar Reinforcement**

Reinforcement bars for concrete shall be hot-rolled, weld able, deformed billet-steel bars conforming to the requirements specified in ASTM A615 and PNS 49 unless shown on the Drawings or as required by the NPC. The use of the cold twisted bars is not permitted. If not otherwise shown on the drawings, the deformed reinforcement steel shall be Grade 60 (minimum yield strength of 410 MPa) for 16 mm  $\Phi$  and bigger bars and Grade 40 (minimum yield strength of 275 MPa) for 12 mm  $\Phi$  and smaller bars. Bar reinforcement shall be shipped in standard bundles, tagged and marked in accordance with the Code of Standard Practice of the Concrete Reinforcement Steel Institute.

**CW-4.2.2 Sampling**

The NPC's Representative will sample reinforcement bars at the source of supply or at the point of distribution, and the Contractor shall notify the NPC in sufficient time advance to permit sampling and testing before shipment is made. Three (3) samples from each size shall be taken at random representing five (5) tons or fraction thereof of each size.

**CW -4.3. Construction Requirement****CW-4.3.1 Order List for Bent Bars**

Before materials are ordered, the Contractor shall furnish all order lists and bending diagrams for the approval of the NPC. The approval of order lists and bending diagrams by the NPC shall in no way relieve the Contractor of responsibility for the correctness of such lists and such lists and diagrams. Any expenses incident to the revisions of materials furnished in accordance with such lists and diagrams to make them comply with the drawings shall be borne by the Contractor.

Shop Drawings for Reinforcing Steel (ACI 315): Indicate bending diagrams, assembly diagrams, splicing and laps of bars, shapes, dimensions and details of bar reinforcing, accessories and concrete cover. Do not scale dimensions from structural drawings to determine lengths of reinforcing steel.

**CW-4.3.2 Fabrication**

Bent bar reinforcement shall be cold bent as shown on the drawings or as required by the NPC. Bars shall be bent around circular pin having the following diameters (D) in relation to the diameter of the bar (d):

Bars 6mm $\Phi$ to 20mm $\Phi$ inclusive	D=6d
Bars 25mm $\Phi$ and 28mm $\Phi$	D=8d
Bars 32mm $\Phi$ and greater	D=10d

Bends and hooks in stirrups and lateral ties may be bent to the diameter of the principal bar enclosed therein.

**CW-4.3.3 Protection of Material**

Steel reinforcement shall be protected at all times from injury. When placed in the work, it shall be free from dirt, detrimental scale, paint, oil or other foreign matter. However, when steel has on its surface easily removable and detrimental rust, loose scale or dust, it shall be cleaned by a satisfactory method, approved by the NPC.

Store reinforcement of the different sizes in racks raised above the ground with accurate identification. Protect reinforcing steel from contaminants such as grease, oil and dirt.

**CW-4.3.4 Placing and Fastening Reinforcement & Miscellaneous Material (ACI 301)**

All reinforcement bars, stirrups, hanger bars, wire fabric, spirals and other reinforcing materials shall be provided as indicated in the drawing or required by the specification, together with all necessary wire ties, chairs, screws, supports, and other devices necessary to install and secure the reinforcement properly. All reinforcement, when placed, shall be free from rust, scale, oil, grease, clay, and other coatings, and foreign substances that would reduce or destroy the bond. Rusting of reinforcement shall not reduce the effective cross sectional area of the reinforcement to the extent that the strength is reduced beyond specified values. Heavy, thick rust or loose, flaky rust shall be removed by rubbing with burlap or other approved method, prior to placing. Reinforcement that has bends not shown on the project drawings or on approved shop drawings, or is reduced in section by rusting such that its weight is not within permissible ASTM tolerances, shall not be used. All reinforcement shall be supported and wired together to prevent displacement by construction loads or by the placing of concrete. Unless directed otherwise by the NPC, reinforcement shall not be bent after being partially embedded in hardened concrete. Detailing of reinforcing shall conform to ACI 315. Where cover over reinforcing steel is not specified or indicated, it shall be in accordance with ACI 318

All steel reinforcement shall be accurately placed in position shown on the drawings or as required by the NPC and firmly held there during the placing and setting of the concrete. Bars shall be tied at all intersections except where spacing is less than 30 mm in each direction, when alternate intersections shall be tied. Ties shall fasten on the inside.

Distance from the forms shall be maintained by means of stays, blocks, hangers or other approved supports. Blocks for holding reinforcement from contact with the forms shall be pre-cast mortar blocks of approved shape and

dimensions or approved chairs. Layers of bars shall, be separated by pre-cast mortar blocks or by other equally suitable devices. The use of pebbles, pieces of broken stone or brick, metal pipe and wooden blocks or metal chairs shall not be permitted. Unless otherwise shown on the Drawings or required by the NPC, the minimum distance between bars shall be 40mm. Reinforcement in any member shall be placed and then inspected and approved by the NPC before the placing of concrete commences. Bundled bars shall be tied together at not more than 1.80 meters intervals.

Reinforcement shall be placed accurately and secured. It shall be supported by suitable chairs and spaces or by metal hangers. On the ground, and where otherwise subject to corrosion, concrete or other suitable non-corrodible material shall be used for supporting reinforcement. Where the concrete surface will be exposed to the weather in the finished structure or where rust would impair the appearance or finish of the structure, all reinforcement supports, within specified concrete cover, shall be galvanized or made of a suitable non-corrodible material.

All placement or movement of reinforcing steel after placement, to positions other than indicated or specified, shall be subject to the approval of the NPC.

Concrete protection for reinforcement shall be as indicated, or if not indicated, in accordance with ACI 318.

The minimum concrete cover for reinforcement specified in the bid documents shall take precedence over all permissible reinforcement placement variations; nothing in the variations listed below is to be constructed as permitting violation or compromise thereof:

a. Height of bottom bars	±6mm above form
b. Lengthwise positioning	±50mm of bars
c. Spacing bars in walls and solid slabs	±25mm
d. Spacing bars in beams and footings	±6mm
e. Height of top bars	±6mm
f. Stirrup spacing	
(1) For any one stirrup	±25mm
(2) For over-all group	±25mm of stirrup

Anchors and bolts; including but not limited to those for the machine and equipment bases: frames or edgings, hangers and inserts, door bucks, pipe supports, pipe sleeves, pipe passing through walls, metal ties, conduits, flashing reflects, drains and all other materials in connection with the concrete construction shall, where practicable be placed and secured in position when the concrete is placed. Anchor bolts for machines shall be set to templates, shall be plumbed carefully and checked for location and elevation with an instrument, and shall be held in position rigidly to prevent displacement while concrete is being placed.

#### CW-4.3.5 Splicing

Splicing of reinforcement shall be in accordance with ACI 318, except as indicated otherwise or modified herein. Where splices in addition to those indicated on the drawings are necessary, they shall be approved by the NPC prior to their use. Splices shall not be made in beams, girders, and slabs at

points of maximum stress. Butt splicing shall preferably be used over lapping for bar sizes larger than 32mm $\Phi$ . Splices to be welded shall conform to AWS D1.4; certification of weld ability of the reinforcement by the manufacturer, shall be submitted to the NPC. If the Contractor elects to use butt splicing of reinforcing, he shall submit complete details of the process to be used by the NPC. If the butt splices are used, the Contractor shall ensure that the splice meets the requirements specified herein by performing at least three splices which shall be submitted for tests to a testing laboratory that has been approved for such testing by the NPC. The cost of these shall be borne by the Contractor.

All reinforcement shall be furnished in the full lengths indicated on the Drawings. Splicing of bars, except where shown on the Drawings will not be permitted without the written approval of the NPC. Splices shall be staggered as far as possible and with a minimum separation of not less than 40 bar diameters. Not more than one-third of the bars may be spliced in the same cross section, except where shown on the Drawings.

Unless otherwise shown on the Drawings, bars shall be lapped a minimum distance of:

Splice Type	Grade 40 Min.Lap	But Not Less Than
Tension	24d	300mm
Compression	20d	300mm

Where d is the diameter of the bar. In lapped splices, the bars shall be placed in contact and wired together. Lapped splices will not be permitted at locations where the concrete section is insufficient to provide a minimum clear distance of one and one-third the maximum size of coarse aggregate between the splice and the nearest adjacent bar. Welding of reinforcing steel shall only be done if detailed on the Drawings or if authorized by the NPC in writing. Spiral reinforcement shall be spliced by lapping at least one and half (1 1/2) turns or by butt-welding unless otherwise shown on the drawings.

#### **CW -4.4. Measurement and Payment**

The quantity to be paid for shall be the calculated theoretical number of kilograms of reinforcement steel bars as determined from the net length of the steel shown on the drawings, incorporated in the concrete and accepted.

The weight of deformed bars will be computed from the theoretical weight of the same nominal size as shown in the following tabulation:

Designation	Size (mm)	Weight (kg/m)
#2	6	0.222
#3	10	0.616
#4	12	0.888
#5	16	1.579
#6	20	2.468
#8	25	3.854
#9	28	4.833
#10	32	6.313
#11	36	7.991

Clips, ties, separators and other and related materials used for positioning and fastening the reinforcement in place as required by the NPC shall not be included in the weight-calculated payment under this item. If bars are substituted upon the Contractor's request and as result, more steel is used than specified; only the amount specified shall be included.

When laps are made for splices, other than those shown on the drawings or required by the NPC and for the convenience of the Contractor, the extra steel shall not be measured nor paid for.

The accepted quantity shall be paid at the corresponding unit price for the item, Reinforcing Steel as shown in the Bill of Quantities which price and payment shall be made in full compensation for furnishing materials, labor, equipment and incidentals necessary to complete this item.

**CW - 5.0      STRUCTURAL STEEL****CW -5.1.      General**

This section covers the fabrication, erection, and shop painting of structural steel in accordance with the AISC "Manual of Steel Construction" referred to herein. In the AISC "Manual of Steel Construction" referred to herein, the Specification for Design, Fabrication, and Erection of Structural Steel for Buildings," and "Structural Joints using A325 or A490 Bolts" shall be considered a part thereto.

**CW-5.1.1 Submittals**

**Shop Drawings:** Submit shop drawings of all structural steel in five (5) copies for approval prior to fabrication of structural steel. Include complete information necessary for the fabrication and erection of the component parts of the structure including the location, type and size of all bolts and welds, member sizes and lengths, camber & connector details, blocks, copes, and cuts. Include all welds by standard welding symbols.

**Erection Plan:** Submit descriptive data to illustrate the structure steel erection procedure including the sequence of erection and temporary shoring and bracing, and written description of the detailed sequence of all welding, including each welding procedure to be performed.

**Certificates of Conformance:**

Submit certificates of conformance for the following:

- Bolts, Nuts and Washers
- Welding Electrodes and Rods
- Paint
- Steel
- Certified Test Reports

**Structural Steel:**

Chemical analysis and tensile strength test required by ASTM, ASTM A53

**High Strength Bolts and Nuts:**

Chemical analysis, tensile strength and hardness test required by ASTM A325.

**CW-5.1.2 Delivery and Storage:**

Handle, ship, and store material in a manner that will prevent distortion or other damage. Store material in a clean and properly drained location and out of contact with the ground. Replace all damaged material with new material or repair the damaged material in an approved manner at no additional cost to the NPC.

**CW -5.2.      Materials**

All materials shall be of the best quality of their kind, well graded and within the allowable distortions, however, they shall be free from flakes, corrosion, scale or fragments that could reduce the resistance and durability or injure the external appearance.



Except as modified herein, blast clean surfaces in accordance with SSPC SP6. Wash clean surfaces that become contaminated with rust, dirt, oil, grease or other contaminants with solvents until thoroughly clean. Ensure that steel to be embedded in concrete and surfaces when assembled, are free from rust, grease, dirt and other foreign matter.

#### CW-5.2.1 Steel

Materials shall conform to the respective specifications specified herein. Materials not otherwise specified herein shall conform to the AISC "manual of Steel Construction".

Structural Steel: ASTM A36  
Steel Pipe: ASTM A53, Type E or S, Grade B, ASTM A501.  
Steel W-Shape Piles  
(Soldier Piles): ASTM A328

#### CW-5.2.2 Bolts, Nuts and Washers:

All bolts, nuts and washers shall be of hot-dip galvanized steel.

Bolts: ASTM A307, Grade C or ASTM A36 for Anchor Bolts;  
ASTM A325 for Fastening Bolts.

Nuts: ASTM A563, Grade A, heavy hex style, except nuts less than 38mm may be provided in hex style.

Washers: ANSI B18.22.1, Type B.

#### CW-5.2.3 Accessories:

Welding Electrodes  
and Rods: Steel structural members shall use E70XX electrodes.

Non-shrink Grout; ASTM C827; non-metallic.

### **CW -5.3. Execution**

#### CW-5.3.1 Fabrication:

Fabricate in accordance with the applicable provisions of the Specification for the Design, Fabrication, and Erection of Structural Steel for Buildings as set forth in the AISC "Manual of Steel Construction".

#### CW-5.3.2 Welding of Structural Steelwork:

All welding works shall be as indicated on the drawings and shall conform to AWS D1.1 - 77 "Structural Welding Code". Unless specified on the drawings, fillet welds shall be a minimum of 5 mm (3/16") and welding electrodes shall be with a tensile strength of 485 MPa.

All welding works shall be executed by the AWS D1.1 qualified welders, welding operators and trackers, whose workmanship shall be subject to the approval of NPC.

**CW-5.3.3 Shop painting:**

Except as otherwise specified, shop prime surfaces of all structural steel, except steel to be embedded in concrete or mortar. Surfaces to be welded shall not be coated within 12 mm from the specified top of the weld prior to welding. Insure that the surfaces are thoroughly dry and clean when the paint is applied. Do not paint on wet weather except under cover. Do not apply paint to steel, which is at a temperature that will cause blistering or porosity, or will otherwise be detrimental to the life of the paint. Apply paint in a workmanlike manner, and coat all joints and crevices thoroughly. Prior to assembly, paint all surfaces that will be concealed or inaccessible after assembly.

Shop prime coat surfaces as soon as possible after cleaning. Apply one coat of inorganic zinc to a minimum dry film thickness of 100 microns.

- **Field painting:** When the erection work is complete, the heads of field bolts, all welds and any surface from which the shop coat of paint has become worn off or has otherwise become defective, shall be cleaned and thoroughly covered with one coat of shop coat paint. When the paint applied for touching up bolt heads and abraded surfaces has become thoroughly dry, apply two field coats of marine epoxy paint subject to the approval of NPC.
- **Marking:** Prior to erection, members shall be provided with a painted erection mark. In addition, connecting parts assembled in the shop for remaining holes in field connections shall be matched marked with scratch and notch marks. Do not locate erection markings on areas to be welded. Do not locate erection markings in areas that will decrease member strength or cause stress concentrations.

**CW-5.3.4 Erection:**

Except as modified herein, erect steel in accordance with the AISC "Manual of Steel Construction". Where parts cannot be assembled or fitted properly as a result of errors in fabrication or of deformation due to handling or transportation, report such condition immediately to the NPC's Representative and obtain approval there from for the methods of correction for straightening, including members of steel conforming to ASTM A514.

Drain Steel work properly; fill pockets in structures exposed to the weather with an approved waterproof material.

Provide safety belts and lines for workmen aloft on high structures unless safe working platforms or safety nets are provided.

When calibrated wrenches are used for tightening bolts, calibrate them at least one each working day using not less than three typical bolts of each diameter. Do not use impact torque wrenches to tighten anchor bolts set in concrete.

**Connections:** Connections shall be executed as shown on drawing. In case, connections are not detailed, it shall be designed in accordance with AISC "Manual of Steel Construction". Build connections into the existing work. Punch, sub-punch and ream, or drill bolt holes.

Tolerances: Structural steel shall be furnished and installed to the lines and levels as shown on the drawings.

Any structure that does not conform shall be repaired, removed and/or erected anew by the Contractor at no additional cost to NPC.

Tolerances on structural steel shall be in accordance with the "Code of Standard Practice" of the AISC "Manual of Steel Construction".

#### **CW-5.3.5 Tests and Inspections:**

##### **Visual Inspection of Welding:**

After the welding is completed, hand or power wires brush welds, thoroughly clean them before the inspector makes the check inspection. Inspect welds with magnifiers under strong, adequate light for surface cracking, porosity, and slag inclusions; excessive roughness; unfilled craters; gas pockets; undercuts; overlaps; size and insufficient throat and concavity. Inspect the preparation of groove welds for adequate throat opening and for snug positioning of backup bars.

##### **Non-Destructive Testing:**

In accordance with AWS D1.1 Twenty-five percent (25%) of the total number of joints, as selected by the NPC, shall be tested. If more than 20 percent of welds contain defects identified by testing, then all welds shall be tested by radiographic or ultrasonic testing, and to be approved by the NPC. When all welds made are required to be tested, magnetic particle testing shall be used only in areas inaccessible to either radiographic or ultrasonic testing. Retest defective areas after repair.

#### **CW -5.4. Measurement and Payment**

Measurement for payment for structural steel shall be based on the total kilograms of structural steel placed and accepted.

Payment will be made at the contract unit price for the item Structural Steel in the Bill of Quantities, which payment shall constitute full compensation for furnishing all labor and equipment necessary to complete the item.

**CW - 6.0 MISCELLANEOUS STEEL****CW -6.1. Scope**

This sections covers performance of all work in connection with miscellaneous steel work including but not limited to handrails, ladders, and hatch opening, pit and trench covers, embedded plates, conduit, pipe items, all complete with anchoring devices, bolts and fastenings. The Contractor shall furnish materials, fabricate, assemble, install and paint all miscellaneous steel works.

**CW -6.2. Shop Drawings**

Complete shop and erection drawings of all miscellaneous steelworks showing sizes, methods of assembly, hardwares and anchorage details, shall be furnished by the Contractor subject to approval of the NPC.

**CW -6.3. Materials**

The materials furnished by the Contractor under this section shall conform to the following standards:

<u>Materials</u>	<u>Standard</u>
Structural Steel (columns, girders, beams, bracing, ladders, hatch opening, pit and trench cover, embedded plates, etc.)	ASTM A36" Specification for Structural Steel" or equivalent Standard.
Black Pipe (pipe railings and pipe for drains)	ASTM 120" Specifications for Black and Hot-Dipped Zinc Coated and Welded and Seamless Steel Pipe for Ordinary Uses"
Steel Grating	ASTM A36 or equivalent
Steel Checkered Plate (Cable Trench Cover)	ASTM A36 or equivalent

Material not specifically designated above shall comply, as far as practicable, with the latest specifications of the ASTM or other approved standards.

The names of the manufacturers of material shall be furnished for approval.

**CW -6.4. Workmanship**a. General

All works shall be executed by a technician skilled in the work and all workmanship and material shall be subject to the approval of the NPC. All miscellaneous steelwork shall be carefully and accurately assembled in the most satisfactory manner to carry out the design shown on the drawings. All joints shall be milled or machined as may be necessary to secure, close and perfect connections. Items shall be carefully

assembled and the component parts shall be well secured together by welding or with screws, bolts and rivets, and concealed as far as possible. Member shall not be over stressed during the process or erection and hammering that will injure or distort the members shall not be permitted. Built-up works shall be assembled completely at the shop, accurately finished and section match-marked for field erection.

The Contractor shall furnish all welding rods required for field welds and all anchors, temporary bracing, tie rods, shims, erection bolts, and other miscellaneous materials required during erection.

b. Embedded Steel Plate

The Contractor shall furnish, fabricate and install all embedded steel plates necessary for pipes, cable trays, duct equipment and installations and supports in accordance with the approved shop drawings or as directed by the NPC. All embedded steel plates shall be accurately set in place at the time when concrete is placed.

c. Steel Checkered Plates

The contractor shall place or install the steel checkered plates in accordance with the approved construction drawings and specifications, or as directed by the NPCs. Fabricated steel checkered plates of ASTM Standards including reinforcing angles, plates, supporting members and anchoring devices shall be furnished by the Contractor.

d. Welding

The welding shall be in accordance with the Code of Arc-end Gas Welding in Building Construction, as formulated by the American Welding Society.

All welding shall be continuous along entire line of contract except where tack welding is permitted. All exposed welds shall be ground smooth.

e. Painting

Painting is included in the applicable bid prices for the various items in the Bill of Quantities.

**CW -6.5. Measurement and Payment**

Measurement for payment will be based on the total kilogram of materials placed or installed in accordance with the drawings or as directed by the NPC.

Payment will be made at the unit bid price for the item, Miscellaneous Steel, in the Bill of Quantities. The unit price shall include all costs of fabrications, supply of reinforcing materials including supports, handling, placing, painting and other incidentals necessary for the completion of work.

**CW - 7.0 PRE-STRESSED CONCRETE PILES****CW -7.1. Scope**

This section shall consist of the furnishing, driving and cutting of pre-stressed concrete piles in accordance with these specifications and in conformity with Drawings and/or as directed by NPC.

The sizes, reinforcement and compressive strength of pre-stressed piles shall be as shown on the Drawings.

**CW -7.2. Material Requirements**

- a. Pre-stressed piles shall be made in accordance with the Drawings, and reinforcement shall be placed accurately and secured rigidly in such manner as to insure its proper location in the completed pile. The concrete cover as measured from the outside face of ties or spirals shall not be less than 20mm.
- b. The piles shall be cast separately or, if alternate piles are cast in a tier, the intermediate piles shall not be cast until 4 days after the adjacent piles have been poured. Piles cast in tiers shall be separated by-tar paper or other suitable separating material. The concrete in each pile shall be placed continuously. The completed piles shall be free from stone pockets, porous spots, or other defects, and forms shall be straight and true and built of metal, plywood, or dressed lumber.
- c. Piles shall be cured in accordance with the generally accepted standards.
- d. Piles shall not be moved until the tests indicate a compressive strength of 80% of the design 28-day compressive strength is attained and they shall not be driven until the tests indicate a compressive strength at least equal to the design 28-day compressive strength.
- e. When concrete piles are lifted or moved, they shall be supported at the points on the Drawings, or if not shown, as instructed by NPC.

**CW -7.3. Preparation for Driving**

Piles shall not be driven until after all preparatory works are completed. Pile templates, if to be constructed, shall be rigidly secured to ensure that piles are driven to their accurate locations. The heads of piles shall be cut squarely and a driving cap shall be provided to hold the axis of the pile in line with the axis of the hammer.

Full-length piles shall be used. Splicing of piles shall not be allowed if test piles showed that the required pile length is less than 30 m. In case splicing is permitted on exceptional circumstance and when required length exceeds 30 m, the method of splicing shall be subject to approval of NPC.

**CW -7.4. Test Piling**

The contractor shall first cast or order 1 test pile as indicated in the plan and of greater length than that assumed in the design to provide for any variation in soil condition but ranges from 20 to 30meters. The test pile shall be driven to refusal or as directed by NPC. Since a test piles will become part of the

completed structures, its location will be as indicated in the drawings or as directed by NPC. The results of driving the test pile shall be submitted immediately to NPC for the determination of the actual length of the remaining piles to be ordered, furnished and delivered at the site. The actual pile lengths based from the result of the test pile shall be the basis for payment. However, pertinent provisions regarding penetration depths and the specified bearing values shall not be disregarded.

#### **CW -7.5. Pile Driving**

- a. All piles shall be driven accurately as shown on the drawings. Each pile, after driving shall be within 150 mm from the theoretical location underneath the pile cap or underneath the superstructure in case of pile bents. Inclination of vertical piles shall be within 1/75. Tolerance of level of pile shall be within 5 cm. The axis can deviate by up to 10% of the pile length for raking piles, provided the pile axis is driven straight.
- b. Piles shall be driven to the minimum depths shown on the drawings or deeper if necessary to achieve the required final set.
- c. All pile driving equipment is subject to the approval of NPC. The Contractor is responsible for sufficient weight and efficiency of the hammer to drive the piles down to the required depth and bearing capacity. Diesel hammer shall be used.
- d. Piles shall be supported in line and position with leads and shall be constructed in such a manner as to afford freedom of movement of the hammer, and shall be held in position by guys or steel braces to insure rigid lateral support to the pile during driving. The leads shall be of sufficient length to make the use of a follower unnecessary. The driving of pile with follower shall be avoided if practicable and shall be done only under written permission from the NPC.
- e. The method used in driving piles shall not subject them to excessive and undue abuse producing crushing and spalling of concrete. Manipulation of piles to force them into proper position will not be permitted.
- f. The pile tops shall be protected by driving heads, caps or cushions in accordance with the recommendations of the manufacturer of pile hammer. The driving head shall be provided to maintain the axis of the pile in line with the axis of the hammer and provide a driving surface normal to the pile.
- g. Full-length piles shall be used where practicable. All piles shall be continuously driven unless otherwise allowed by NPC.
- h. In pile cluster, pile driving shall start at the center progressing outward in all directions. During driving, as the resistance increases, the rate of penetration is noted, generally by one foot markings on the pile, and when this rate has decreased considerably, the average penetration in inches per blow for the last 10 blows for diesel hammer shall be recorded and the safe bearing capacity of the pile is computed from the pile formulas. The safe bearing capacity shall be as called for in the drawings.
- i. All piles shall be driven until the minimum penetration obtained is satisfactory to NPC, regardless of the fact that the required bearing, as

determined by the pile formulas, may be obtained at a lesser depth.

#### **CW -7.6. Cutting of Piles**

- a. Tops of piles shall be embedded in the concrete capping as shown on the drawings.
- b. Concrete piles shall, when approved by NPC, be cut off at such level as shown on the drawings. If a pile is damaged below this level, the Contractor shall repair the pile in accordance with the procedure approved by NPC. The distance from the side of any pile to the nearest edge of the cap shall not be less than 300 mm.
- c. When the cut-off elevation for a prestressed concrete pile is below the elevation of the bottom of the pile cap, the pile may be built up from the butt of the pile to elevation of the bottom of the cap by means of a reinforced concrete extension to be approved by NPC.

#### **CW -7.7. Pile Formula**

For piles not driven to practical refusal and in lieu of loading tests, which are more preferable for piles other than timber piles, the bearing value for the piles shall be approximated by any applicable pile formula for the determination of allowable bearing capacity.

#### **CW -7.8. Pile Records**

The Contractor shall keep records of all piles driven. A copy of the record shall be given to NPC within 2 days after each pile is driven. The record form to be used shall be approved by NPC. The pile records shall give full information on the following:

- a. Pile Type and Dimension
- b. Date of casting and date of driving
- c. Driving equipment: type, weight and efficiency of hammer, etc.
- d. Depth driven and tip elevation
- e. Final set for the last 10 blows (for each group of pile and when the NPC so required, the penetration along the whole driven depth shall be recorded)
- f. Details of any interruption in driving
- g. Level of pile top immediately after driving and the level when all piles in the group are driven
- h. Details of re-driving, if any

On completion of the piling for each structure, the Contractor shall deliver to NPC a drawing recording the exact location and the final depth (tip elevation) of all piles.

#### **CW -7.9. Measurement and Payment**

Measurement for payment for pre-stressed concrete piles, as stated in the Bill of Quantities will be based on the number of piles driven and accepted by NPC times the lengths of piles in linear meters as determined from the result of the test pile.

Payment will be made at the contract unit price for the item Pre-stressed



Concrete Piles which payment shall constitute full compensation for furnishing all materials, labor, equipment and tools necessary to complete the item, including scaffoldings, supports and other incidentals attendant to pile driving.

Rejected piles shall not be included for payment.

**CW - 8.0 FENDER SYSTEM****CW -8.1. General**

This section covers the furnishing, delivery and installation of fender system in accordance with these specifications and in conformity with the drawings.

**CW -8.2. Materials**

Rubber fenders shall be rubber tire (used) with sizes as indicated in the drawings.

**CW -8.3. Anchorage Fastening**

Fastening details, anchors, bolts and nuts shall be stainless steel conforming to ASTM F-593 "Standard Specification for Stainless Steel Bolts, Hex Cap Screws, and Studs". The size and quantity of these accessories shall be determined in accordance with the capacity of the fender system and subject to NPC's approval.

All works shall be performed with the highest acceptable quality and completed in a thorough and workmanlike manner and shall follow the best modern practices in installation. The Contractor shall furnish all fastening, anchors and temporary bracings and other miscellaneous materials required during installation of rubber fenders.

**CW -8.4. Measurement and Payment**

Measurement for payment will be based on the number of fender system assembly installed and accepted by NPC.

Payment will be made at the contract unit price for the item, Rubber Fender in the Bill of Quantities, which payment shall include all costs of materials, labor, tools and incidentals including anchor bolts needed to complete the installation of the fender system.

## SECTION IV

# BILL OF QUANTITIES

SECTION IV - BILL OF QUANTITIES

**CIVIL WORKS**

Item No.	Description of Work or Materials	Work to Be Done	Ref.	Unit	Estimated Quantity	Unit Price in Pesos (Words and Figures)	Total Amount
<b>A. BREASTING DOLPHINS/STRUCTURES</b>							
a.	Pre-stressed Concrete Piles Length=30m/pc (12 pcs) (see drawing for details)	supply, deliver, handle, pitch drive, cut and splice	CW-7	l.m.	360	_____ (P _____)	P _____
b.	Concrete Pile Cap (20.7 MPa)	furnish and construct	CW-3	cu. m.	30	_____ (P _____)	P _____
c.	Reinforcing Steel	furnish, cut bend and install	CW-4	kg	4,700	_____ (P _____)	P _____
d.	Rubber Fender (used tire) including bolts, nuts, anchorage, etc.	furnish and install	CW-8	set	2	_____ (P _____)	P _____
<b>TOTAL AMOUNT (CIVIL WORKS)</b>						_____ (P _____)	P _____

\_\_\_\_\_  
Name of Firm

\_\_\_\_\_  
Name and Signature of Authorized Representative

\_\_\_\_\_  
Designation



# SECTION V

# **BIDDING FORMS**



## SECTION V – BIDDING FORMS

### TABLE OF CONTENTS

NPCSF-INFR-01	- Checklist of Technical and Financial Envelope Requirements for Bidders
NPCSF-INFR-02	- List of all Ongoing Government & Private Construction Contracts Including Contracts Awarded but not yet Started
NPCSF-INFR-03	- Statement of the bidder's Single Largest Completed Contract (SLCC) similar to the contract to be bid
NPCSF-INFR-04	- Computation of Net Financial Contracting Capacity (NFCC)
NPCSF-INFR-05	- Joint Venture Agreement
<i>NPCSF-INFR-06</i>	- <i>NOT USED</i>
NPCSF-INFR-07	- Omnibus Sworn Statement (Revised)
NPCSF-INFR-08	- Contractor's Organizational Chart for the Project
NPCSF-INFR-09	- List of Key Personnel Proposed to be Assigned to the Project
NPCSF-INFR-10a	- Key Personnel's Certificate of Employment (Professional Personnel)
NPCSF-INFR-10b	- Key Personnel's Certificate of Employment (Construction Safety and Health Officer)
NPCSF-INFR-11	- Key Personnel's Bio-Data
NPCSF-INFR-12	- List of Equipment, Owned or Leased and/or under Purchase Agreement, Pledged to the Proposed Project
NPCSF-INFR-13	- Bid Letter
NPCSF-INFR-14	- Detailed Cost Estimate Form
NPCSF-INFR-15	- Summary Sheets of Materials Prices, Labor Rates and Equipment Rental Rates

Standard Form No: NPCSF-INFR-01

**Checklist of Technical & Financial Envelope Requirements for Bidders****A. THE 1<sup>ST</sup> ENVELOPE (TECHNICAL COMPONENT) SHALL CONTAIN THE FOLLOWING:****1. ELIGIBILITY DOCUMENTS****a. (CLASS A)**

## ➤ Any of the following:

- PhilGEPS Certificate of Registration and Membership under Platinum Category in accordance with Section 8.5.2 of the IRR;

**OR:**

- The following updated and valid Class "A" eligibility documents enumerated under "Annex A" of the Platinum Membership:

- Registration Certificate from the Securities and Exchange Commission (SEC) for corporations, Department of Trade and Industry (DTI) for sole proprietorship, or Cooperative Development Authority (CDA) for cooperatives;

- Mayor's/Business permit issued by the city or municipality where the principal place of business of the prospective bidder is located, or the equivalent document for Exclusive Economic Zones or Areas.

In cases of recently expired Mayor's/Business permits, it shall be accepted together with the official receipt as proof that the bidder has applied for renewal within the period prescribed by the concerned local government unit, provided that the renewed permit shall be submitted as a post qualification requirement in accordance with Section 34.2 of the Revised IRR of RA 9184.

- The prospective bidder's audited financial statements, showing, among others, the prospective bidder's total and current assets and liabilities, stamped "received" by the BIR or its duly accredited and authorized institutions, for the preceding calendar year which should not be earlier than two (2) years from the date of bid submission.
- Tax clearance per Executive Order 398, Series of 2005, as finally reviewed and approved by the BIR;
- Valid Philippine Contractors Accreditation Board (PCAB) license and registration for the type and cost of the contract for this Project or Special PCAB License in case of Joint Ventures.

**OR:**

- A combination thereof.

➤ Statement of all its ongoing government and private contracts if any, whether similar or not similar in nature and complexity to the contract to be bid (*NPCSF-INFR-02*)

➤ The Statement of the bidder's Single Largest Completed Contract (SLCC) similar to the contract to be bid, and whose value, adjusted to current prices using the Philippine Statistics Authority (PSA) consumer price index, must be at least 50% of the ABC (*NPCSF-INFR-03*) complete with the following supporting documents:

- Contract/Purchase Order
- Owner's Certificate of Final Acceptance issued by the project owner other than the contractor or a final rating of at least Satisfactory in the Constructors Performance Evaluation System (CPES). In case of contracts with the private sector, an equivalent document (Ex. Official Receipt or Sales Invoice) shall be submitted

*(The Single Largest Completed Contract (SLCC) as declared by the bidder shall be verified and validated to ascertain such completed contract. Hence, bidders must ensure access to sites of such projects/equipment to NPC representatives for verification and validation purposes during post-qualification process.*

*It shall be a ground for disqualification, if verification and validation cannot be conducted due to inaccessibility of the site for whatever reason or fault of the bidder.)*

- Special PCAB License in case of Joint Ventures
- Duly signed computation of its Net Financial Contracting Capacity (NFCC) at least equal to the ABC (NPCSF-INFR-04);

**b. (CLASS B)**

- Valid Joint Venture Agreement, if applicable (NPCSF-INFR-05)

**2. Technical Documents**

- Duly signed, completely filled-out and notarized Omnibus Sworn statement (Revised) (NPCSF-INFR-07), complete with the following attachments:
  - For Sole Proprietorship:
    - Special Power of Attorney
  - For Partnership/Corporation/Cooperative/Joint Venture:
    - Document showing proof of authorization (e.g., duly notarized Secretary's Certificate, Board/Partnership Resolution, or Special Power of Attorney, whichever is applicable)
- Organization Chart for the project (NPCSF-INFR-08)
- Duly Signed List of Contractor's Key Personnel (based on the minimum key personnel) with complete supporting documents (NPCSF-INFR-09, 10a, 10b & 11)
- Duly Signed List of Contractor's Equipment (owned, leased or under purchase agreement (NPCSF-INFR-12), with
  - Proof of ownership and/or certificate of availability issued by Equipment Lessors
- Complete eligibility documents of proposed sub-contractor, if applicable

**B. THE 2<sup>ND</sup> ENVELOPE (FINANCIAL COMPONENT) SHALL CONTAIN THE FOLLOWING:**

- Duly signed Bid Letter indicating the total bid amount in accordance with the prescribed form (NPCSF-INFR-13)
- Duly signed and completely filled-out Bill of Quantities (Section IV) indicating the unit and total prices per item and the total amount in the prescribed Bill of Quantities form.
- Duly Signed Detailed Estimates for each items of work showing the computations in arriving at each item's unit prices used in coming up with the bid (NPCSF-INFR-14)
- Summary sheets indicating the direct unit prices of construction materials, labor rates and equipment rental rates used in coming up with the bid (NPCSF-INFR-15)



Standard Form No: NPCSF-INFR-01  
Page 3 of 3

**CONDITIONS:**

1. *Each Bidder shall submit one copy of the first and second components of its Bid. NPC may request additional hard copies and/or electronic copies of the Bid. However, failure of the Bidders to comply with the said request shall not be a ground for disqualification.*
2. *A Bidder not submitting bid for reason that his cost estimate is higher than the ABC, is required to submit his letter of non-participation/regret supported by corresponding detailed estimates. Failure to submit the two (2) documents shall be understood as acts that tend to defeat the purpose of public bidding without valid reason as stated under Section 69.1.(i) of the revised IRR of R.A. 9184.*

Standard Form Number: NPCSF-INFR-02

**List of All Ongoing Government and Private Contracts Including Contract Awarded But Not Yet Started**

Business Name : \_\_\_\_\_  
Business Address : \_\_\_\_\_

Name of Contract/Location/ Project Cost	a. Owner's Name b. Address c. Telephone Nos.	Nature of Work	Contractor's Role		a. Date Awarded b. Date Started c. Date of Completion or Estimated Completion Time	Value of Outstanding Works
			Description	%		
<u>Government</u>						
<u>Private</u>						
					<b>Total Cost</b>	

The bidder shall declare in this form all his on-going government and private contracts including contracts where the bidder (either as individual or as a Joint Venture) is a partner in a Joint Venture agreement other than his current joint venture where he is a partner. Non declaration will be a ground for disqualification of bid.

Note : This statement shall be supported with the following documents for all the contract(s) stated above which shall be submitted during Post-qualification:

1. Contract/Purchase Order and/or Notice of Award
2. Certification coming from the project owner/client that the performance is satisfactory as of the bidding date.

Submitted by : \_\_\_\_\_  
(Printed Name & Signature)  
Designation : \_\_\_\_\_  
Date : \_\_\_\_\_



Standard Form Number: NPCSF-INFR-03

**The Statement of the bidder's Single Largest Completed Contract (SLCC) similar to the contract to be bid**

Business Name : \_\_\_\_\_  
Business Address : \_\_\_\_\_

Name of Contract	a. Owner's Name b. Address c. Telephone Nos.	Nature of Work	Contractor's Role		a. Amount at Award b. Amount at Completion c. Duration	a. Date Awarded b. Contract Effectivity c. Date Completed
			Description	%		

- Notes: 1. The bidder must state only one (1) Single Largest Completed Contract (SLCC) similar to the contract to be bid.  
2. Supporting documents such as Contract/Purchase Order and any of the following: Owner's Certificate of Final Acceptance issued by the project owner other than the contractor; or A final rating of at least Satisfactory in the Constructors Performance Evaluation System (CPES); or Official Receipt (O.R); or Sales Invoice for the contract stated above shall be submitted during Bid Opening.

Submitted by \_\_\_\_\_  
(Printed Name & Signature)  
Designation : \_\_\_\_\_  
Date : \_\_\_\_\_

Standard Form Number: NPCSF-INFR-04

**NET FINANCIAL CONTRACTING CAPACITY (NFCC)**

- A. Summary of the Bidder's/Contractor's assets and liabilities on the basis of the income tax return and audited financial statement for the immediately preceding calendar year are:

		Year 20__
1.	Total Assets	
2.	Current Assets	
3.	Total Liabilities	
4.	Current Liabilities	
5.	Net Worth (1-3)	
6.	Net Working Capital (2-4)	

- B. The Net Financial Contracting Capacity (NFCC) based on the above data is computed as follows:

NFCC = [(Current assets minus current liabilities) x 15] minus the value of all outstanding or uncompleted portions of the projects under ongoing contracts, including awarded contracts yet to be started coinciding with the contract for this Project.

NFCC = P \_\_\_\_\_

Herewith attached is certified true copy of the audited financial statement, stamped "RECEIVED" by the BIR or BIR authorized collecting agent for the immediately preceding calendar year.

Submitted by:

\_\_\_\_\_  
Name of Bidder/Contractor

\_\_\_\_\_  
Signature of Authorized Representative

Date : \_\_\_\_\_

Standard Form Number: NPCSF-INFR-05

**JOINT VENTURE AGREEMENT**

**KNOW ALL MEN BY THESE PRESENTS:**

That this JOINT VENTURE AGREEMENT is entered into by and between:  
\_\_\_\_\_, of legal age, *(civil status)* \_\_\_\_\_, authorized representative of  
\_\_\_\_\_ and a resident of \_\_\_\_\_.

- and -

\_\_\_\_\_, of legal age, *(civil status)* \_\_\_\_\_, authorized representative of  
\_\_\_\_\_ a resident of \_\_\_\_\_.

That both parties agree to join together their capital, manpower, equipment, and other resources and efforts to enable the Joint Venture to participate in the Bidding and Undertaking of the hereunder stated Contract of the **National Power Corporation**.

**NAME OF PROJECT**

**CONTRACT AMOUNT**

That the capital contribution of each member firm:

NAME OF FIRM	CAPITAL CONTRIBUTION
1.	<b>P</b>
2.	<b>P</b>

That both parties agree to be jointly and severally liable for their participation in the Bidding and Undertaking of the said contract.

That both parties agree that \_\_\_\_\_ and/or \_\_\_\_\_ shall be the Official Representative/s of the Joint Venture, and are granted full power and authority to do, execute and perform any and all acts necessary and/or to represent the Joint Venture in the Bidding and Undertaking of the said contract, as fully and effectively and the Joint Venture may do and if personally present with full power of substitution and revocation.

That this Joint Venture Agreement shall remain in effect only for the above stated Contract until terminated by both parties.

\_\_\_\_\_  
*Name & Signature of Authorized Representative*

\_\_\_\_\_  
*Name & Signature of Authorized Representative*

\_\_\_\_\_  
*Official Designation*

\_\_\_\_\_  
*Official Designation*

\_\_\_\_\_  
*Name of Firm*

\_\_\_\_\_  
*Name of Firm*

Witnesses

1. \_\_\_\_\_

2. \_\_\_\_\_

**[Jurat]**

*[Format shall be based on the latest Rules on Notarial Practice]*

Standard Form No: NPCSF-INFR-07

### Omnibus Sworn Statement (Revised)

REPUBLIC OF THE PHILIPPINES )  
CITY/MUNICIPALITY OF \_\_\_\_\_ ) S.S.

#### AFFIDAVIT

I, [Name of Affiant], of legal age, [Civil Status], [Nationality], and residing at [Address of Affiant], after having been duly sworn in accordance with law, do hereby depose and state that:

1. *[Select one, delete the other:]*

*[If a sole proprietorship:]* I am the sole proprietor or authorized representative of [Name of Bidder] with office address at [address of Bidder];

*[If a partnership, corporation, cooperative, or joint venture:]* I am the duly authorized and designated representative of [Name of Bidder] with office address at [address of Bidder];

2. *[Select one, delete the other:]*

*[If a sole proprietorship:]* As the owner and sole proprietor, or authorized representative of [Name of Bidder], I have full power and authority to do, execute and perform any and all acts necessary to participate, submit the bid, and to sign and execute the ensuing contract for [Name of the Project] of the [Name of the Procuring Entity], as shown in the attached duly notarized Special Power of Attorney;

*[If a partnership, corporation, cooperative, or joint venture:]* I am granted full power and authority to do, execute and perform any and all acts necessary to participate, submit the bid, and to sign and execute the ensuing contract for [Name of the Project] of the [Name of the Procuring Entity], as shown in the attached [state title of attached document showing proof of authorization (e.g., duly notarized Secretary's Certificate, Board/Partnership Resolution, or Special Power of Attorney, whichever is applicable)];

3. [Name of Bidder] is not "blacklisted" or barred from bidding by the Government of the Philippines or any of its agencies, offices, corporations, or Local Government Units, foreign government/foreign or international financing institution whose blacklisting rules have been recognized by the Government Procurement Policy Board, by itself or by relation, membership, association, affiliation, or controlling interest with another blacklisted person or entity as defined and provided for in the Uniform Guidelines on Blacklisting;

4. Each of the documents submitted in satisfaction of the bidding requirements is an authentic copy of the original, complete, and all statements and information provided therein are true and correct;

5. [Name of Bidder] is authorizing the Head of the Procuring Entity or its duly authorized representative(s) to verify all the documents submitted;

6. *[Select one, delete the rest:]*

*[If a sole proprietorship:]* The owner or sole proprietor is not related to the Head of the Procuring Entity, members of the Bids and Awards Committee (BAC), the Technical Working Group, and the BAC Secretariat, the head of the Project Management Office or the end-user unit, and the project consultants by consanguinity or affinity up to the third civil degree;

*[If a partnership or cooperative:]* None of the officers and members of [Name of Bidder] is related to the Head of the Procuring Entity, members of the Bids and Awards Committee (BAC), the Technical Working Group, and the BAC Secretariat, the head of the Project

*This omnibus statement is a requirement in the Technical Envelope. The following additional requirements shall also be submitted: In the case of corporation/partnership/JV, duly notarized Special Power of Attorney, Board/Partnership Resolution, or Secretary's Certificate, whichever is applicable.*

## SECTION V – BIDDING FORMS

Management Office or the end-user unit, and the project consultants by consanguinity or affinity up to the third civil degree;

*[If a corporation or joint venture:]* None of the officers, directors, and controlling stockholders of *[Name of Bidder]* is related to the Head of the Procuring Entity, members of the Bids and Awards Committee (BAC), the Technical Working Group, and the BAC Secretariat, the head of the Project Management Office or the end-user unit, and the project consultants by consanguinity or affinity up to the third civil degree;

7. *[Name of Bidder]* complies with existing labor laws and standards; and
8. *[Name of Bidder]* is aware of and has undertaken the responsibilities as a Bidder in compliance with the Philippine Bidding Documents, which includes:
  - a. Carefully examining all of the Bidding Documents;
  - b. Acknowledging all conditions, local or otherwise, affecting the implementation of the Contract;
  - c. Making an estimate of the facilities available and needed for the contract to be bid, if any; and
  - d. Inquiring or securing Supplemental/Bid Bulletin(s) issued for the *[Name of the Project]*.
9. *[Name of Bidder]* did not give or pay directly or indirectly, any commission, amount, fee, or any form of consideration, pecuniary or otherwise, to any person or official, personnel or representative of the government in relation to any procurement project or activity.
10. In case advance payment was made or given, failure to perform or deliver any of the obligations and undertakings in the contract shall be sufficient grounds to constitute criminal liability for Swindling (Estafa) or the commission of fraud with unfaithfulness or abuse of confidence through misappropriating or converting any payment received by a person or entity under an obligation involving the duty to deliver certain goods or services, to the prejudice of the public and the government of the Philippines pursuant to Article 315 of Act No. 3815 s. 1930, as amended, or the Revised Penal Code.

IN WITNESS WHEREOF, I have hereunto set my hand this \_\_\_ day of \_\_\_, 20\_\_ at \_\_\_\_\_, Philippines.

*[Insert NAME OF BIDDER OR ITS AUTHORIZED REPRESENTATIVE]*

*[Insert signatory's legal capacity]*  
Affiant

**[Jurat]**

*[Format shall be based on the latest Rules on Notarial Practice]*



Standard Form Number: NPCSF-INFR-08

## CONTRACTOR'S ORGANIZATIONAL CHART FOR THE CONTRACT

Submit Copy of the Organizational Chart that the Contractor intends to use to execute the Contract if awarded to him. Indicate in the chart the names of the Project Manager, Project Engineer, Foreman and other Key Engineering Personnel.

Attach the required Proposed Organizational Chart for the Contract as stated above

### NOTES:

1. *This organization chart should represent the "Contractor's Organization" required for the Project, and not the organizational chart of the entire firm.*
2. *Each such nominated engineer/key personnel shall comply with and submit duly accomplished forms NPCSF-INFR-10a, NPCSF-INFR-10b and NPCSF-INFR-11.*
3. *All these are required to be in the Technical Envelope of the Bidder.*

Standard Form Number: NPCSF-INFR-09

**LIST OF KEY PERSONNEL PROPOSED TO BE ASSIGNED TO THE CONTRACT**  
*(Based on the Minimum Key Personnel Required in the Bidding Documents)*

Business Name: \_\_\_\_\_  
Business: \_\_\_\_\_  
\_\_\_\_\_

	DESIGNATION				
1 Name					
2 Address					
3 Date of Birth					
4 Employed Since					
5 Experience					
6 Previous Employment					
7 Education					
8 PRC License					

**Required Attachments:**

1. *Certificate of Employment, Bio Data and Construction Safety and Health Training Certificate of the Safety Officer*
2. *Certificate of Employment, Bio Data and valid PRC License of the (professional) personnel*
3. *Certificate of Employment, Bio Data and accreditation from DPWH as Materials Engineer for the Materials Engineer*

Submitted by: \_\_\_\_\_  
*(Printed Name & Signature)*

Designation: \_\_\_\_\_

Date: \_\_\_\_\_

*One of the requirements from the bidder to be included in its Technical Envelope is a list of contractor's key personnel (based on the minimum key personnel required in the bidding documents) to be assigned to the contract to be bid, with their complete qualification and experience data (including the key personnel's signed written commitment to work for the project once awarded the contract).*

Standard Form Number: NPCSF-INFR-10a

**KEY PERSONNEL'S CERTIFICATE OF EMPLOYMENT  
(PROFESSIONAL PERSONNEL)**

\_\_\_\_\_  
Issuance Date

**THE PRESIDENT**

National Power Corporation  
BIR Road cor. Quezon Ave.  
Diliman, Quezon City

Dear Sir:

I am (Name of Nominee) a Licensed \_\_\_\_\_ Engineer with Professional License No. \_\_\_\_\_ issued on (date of issuance) at (place of issuance).

I hereby certify that (Name of Bidder) has engaged my services as (Designation) for the (Name of Project), if awarded to it.

As (Designation), I supervised the following completed projects similar to the contract under bidding:

NAME OF PROJECT	OWNER	COST	DATE COMPLETED

At present, I am supervising the following projects:

NAME OF PROJECT	OWNER	COST	DATE COMPLETED

In case of my separation for any reason whatsoever from the above-mentioned Contractor, I shall notify the National Power Corporation at least twenty one (21) days before the effective date of my separation.

As (Designation), I know I will have to stay in the job site all the time to supervise and manage the Contract works to the best of my ability, and aware that I am authorized to handle only one (1) contract at a time.

*One of the requirements from the bidder to be included in its Technical Envelope is a list of contractor's key personnel (viz. Project Manager, Project Engineer, Construction Safety Officer, Foremen, etc), to be assigned to the contract to be bid, with their complete qualification and experience data (including the key personnel's signed written commitment to work for the project once awarded the contract).*

Standard Form Number: NPCSF-INFR-10a  
Page 2 of 2

I do not allow the use of my name for the purpose of enabling the above-mentioned Contractor to qualify for the Contract without any firm commitment on my part to assume the post of (Designation) therefor, if the contract is awarded to him since I understand that to do so will be a sufficient ground for my disqualification as (Designation) in any future National Power Corporation bidding or employment with any Contractor doing business with the National Power Corporation.

\_\_\_\_\_  
(Name and Signature)

AFFIANT

**Jurat**

[Format shall be based on the latest Rules on Notarial Practice]

*One of the requirements from the bidder to be included in its Technical Envelope is a list of contractor's key personnel (viz. Project Manager, Project Engineer, Construction Safety Officer, Foremen, etc), to be assigned to the contract to be bid, with their complete qualification and experience data (including the key personnel's signed written commitment to work for the project once awarded the contract).*

Standard Form Number: NPCSF-INFR-10b

**KEY PERSONNEL'S CERTIFICATE OF EMPLOYMENT  
(CONSTRUCTION SAFETY AND HEALTH OFFICER)**

\_\_\_\_\_  
Issuance Date

**THE PRESIDENT**

National Power Corporation  
BIR Road cor. Quezon Ave.  
Diliman, Quezon City

Dear Sir:

I am (Name of Nominee) an Construction Safety & Health Officer with Certificate No. \_\_\_\_\_ issued on (date of issuance) at (place of issuance).

I hereby certify that (Name of Bidder) has engaged my services as Construction Safety & Health Officer for the (Name of Project), if awarded to it.

I am the Construction Safety & Health Officer of the following completed projects similar to the contract under bidding:

NAME OF PROJECT	OWNER	COST	DATE COMPLETED
_____	_____	_____	_____
_____	_____	_____	_____
_____	_____	_____	_____
_____	_____	_____	_____

At present, I am the Construction Safety & Health Officer of the following projects:

NAME OF PROJECT	OWNER	COST	DATE COMPLETED
_____	_____	_____	_____
_____	_____	_____	_____
_____	_____	_____	_____
_____	_____	_____	_____

In case of my separation for any reason whatsoever from the above-mentioned Contractor, I shall notify the National Power Corporation at least twenty one (21) days before the effective date of my separation.

As Construction Safety & Health Officer, I know I will have to stay in the job site all the time and aware that I am authorized to handle only one (1) contract at a time.

*One of the requirements from the bidder to be included in its Technical Envelope is a list of contractor's key personnel (viz. Project Manager, Project Engineer, Construction Safety Officer, Foremen, etc), to be assigned to the contract to be bid, with their complete qualification and experience data (including the key personnel's signed written commitment to work for the project once awarded the contract).*

Standard Form Number: NPCSF-INFR-10b  
Page 2 of 2

I do not allow the use of my name for the purpose of enabling the above-mentioned Contractor to qualify for the Contract without any firm commitment on my part to assume the post of Construction Safety & Health Officer, if the contract is awarded to him since I understand that to do so will be a sufficient ground for my disqualification as Construction Safety & Health Officer in any future National Power Corporation bidding or employment with any Contractor doing business with the National Power Corporation.

---

(Name and Signature)

AFFIANT

**[Jurat]**

*[Format shall be based on the latest Rules on Notarial Practice]*

*One of the requirements from the bidder to be included in its Technical Envelope is a list of contractor's key personnel (viz. Project Manager, Project Engineer, Construction Safety Officer, Foremen, etc), to be assigned to the contract to be bid, with their complete qualification and experience data (including the key personnel's signed written commitment to work for the project once awarded the contract).*

Standard Form Number: NPCSF-INFR-11

**KEY PERSONNEL  
(FORMAT OF BIO-DATA)**

Give the detailed information of the following personnel who are scheduled to be assigned as full-time field staff for the project. Fill up a form for each person.

1. Name : \_\_\_\_\_
2. Date of Birth : \_\_\_\_\_
3. Nationality : \_\_\_\_\_
4. Education and Degrees : \_\_\_\_\_
5. Specialty : \_\_\_\_\_
6. Registration : \_\_\_\_\_
7. Length of Service with the Firm : \_\_\_\_\_ Year from \_\_\_\_\_ (months) \_\_\_\_\_ (year)  
To \_\_\_\_\_ (months) \_\_\_\_\_ (year)
8. Years of Experience : \_\_\_\_\_
9. If item 7 is less than ten (10) years, give name and length of service with previous employers for a ten (10)-year period (attached additional sheet/s), if necessary:

Name and Address of Employer

Length of Service

_____	_____ year(s) from _____ to _____
_____	_____ year(s) from _____ to _____
_____	_____ year(s) from _____ to _____

10. Experience:

This should cover the past ten (10) years of experience. (Attached as many pages as necessary to show involvement of personnel in projects using the format below).

*One of the requirements from the bidder to be included in its Technical Envelope is a list of contractor's key personnel (viz. Project Manager, Project Engineer, Construction Safety Officer, Foremen, etc), to be assigned to the contract to be bid, with their complete qualification and experience data (including the key personnel's signed written commitment to work for the project once awarded the contract).*

Standard Form Number: NPCSF-INFR-11  
Page 2 of 2

- 1. Name : \_\_\_\_\_
- 2. Name and Address of Owner : \_\_\_\_\_
- 3. Name and Address of the Owner's Engineer (Consultant) : \_\_\_\_\_
- 4. Indicate the Features of Project (particulars of the project components and any other particular interest connected with the project): \_\_\_\_\_
- 5. Contract Amount Expressed in Philippine Currency : \_\_\_\_\_
- 6. Position : \_\_\_\_\_
- 7. Structures for which the employee was responsible : \_\_\_\_\_
- 8. Assignment Period : from \_\_\_\_\_ (months) \_\_\_\_\_ (years)  
: to \_\_\_\_\_ (months) \_\_\_\_\_ (years)

\_\_\_\_\_  
Name and Signature of Employee

It is hereby certified that the above personnel can be assigned to this project, if the contract is awarded to our company.

\_\_\_\_\_  
(Place and Date)

\_\_\_\_\_  
(The Authorized Representative)

*One of the requirements from the bidder to be included in its Technical Envelope is a list of contractor's key personnel (viz. Project Manager, Project Engineer, Construction Safety Officer, Foremen, etc), to be assigned to the contract to be bid, with their complete qualification and experience data (including the key personnel's signed written commitment to work for the project once awarded the contract).*



Standard Form Number: NPCSF-INFR-12

**LIST OF EQUIPMENT, OWNED OR LEASED AND/OR UNDER PURCHASE AGREEMENTS**  
*(Based on the Minimum Equipment Required in the Bidding Documents)*

Business Name: \_\_\_\_\_  
Business: \_\_\_\_\_

Description	Model/Year	Capacity / Performance / Size	Plate No.	Motor No. / Body No.	Location	Condition	Proof of Ownership / Lessor or Vendor
<b>A. Owned</b>							
i.							
ii.							
iii.							
iv.							
v.							
<b>B. Leased</b>							
i.							
ii.							
iii.							
iv.							
v.							
<b>C. Under Purchase Agreements</b>							
i.							
ii.							
iii.							
iv.							
v.							

Submitted by: \_\_\_\_\_  
*(Printed Name & Signature)*

Designation: \_\_\_\_\_

Date: \_\_\_\_\_

*One of the requirements from the bidder to be included in its Technical Envelope is the list of its equipment units pledged for the contract to be bid, based on minimum equipment required in the bidding docs. which are owned (supported by proof/s of ownership), leased, and/or under purchase agreements (with corresponding engine numbers, chassis numbers and/or serial numbers), supported by certification of availability of equipment from the equipment lessor/vendor for the duration of the project*

Standard Form No. : NPCSF-INFR-13

**BID LETTER**

Date: \_\_\_\_\_

To: **THE PRESIDENT**  
National Power Corporation  
BIR Road cor. Quezon Ave.  
Diliman, Quezon City

We, the undersigned, declare that:

(a) We have examined and have no reservation to the Bidding Documents, including Addenda, for the Contract **CONSTRUCTION OF ADDITIONAL BREASTING STRUCTURES FOR POWER BARGE 120 AT MOGPOG, MARINDUQUE (LuzP21Z1352Sc)**.

(b) We offer to execute the Works for this Contract in accordance with the Bid Documents, Technical Specifications, General and Special Conditions of Contract accompanying this Bid;

The total price of our Bid, excluding any discounts offered below is: [insert information] \_\_\_\_\_;

The discounts offered and the methodology for their application are: [insert information] \_\_\_\_\_;

(c) Our Bid shall be valid for a period of [insert number] \_\_\_\_\_ days from the date fixed for the Bid submission deadline in accordance with the Bidding Documents, and it shall remain binding upon us and may be accepted at any time before the expiration of that period;

(d) If our Bid is accepted, we commit to obtain a Performance Security in the amount of [insert percentage amount] \_\_\_\_\_ percent of the Contract Price for the due performance of the Contract;

(e) Our firm, including any subcontractors or suppliers for any part of the Contract, have nationalities from the following eligible countries: [insert information] \_\_\_\_\_;

(f) We are not participating, as Bidders, in more than one Bid in this bidding process, other than alternative offers in accordance with the Bidding Documents;

(g) Our firm, its affiliates or subsidiaries, including any subcontractors or suppliers for any part of the Contract, has not been declared ineligible by the Funding Source;

(h) We understand that this Bid, together with your written acceptance thereof included in your notification of award, shall constitute a binding contract between us, until a formal Contract is prepared and executed; and

(i) We understand that you are not bound to accept the Lowest Calculated Bid or any other Bid that you may receive.

(j) We likewise certify/confirm that the undersigned, is the duly authorized representative of the bidder, and granted full power and authority to do, execute and perform any and all acts necessary to participate, submit the bid, and to sign and execute the ensuing contract for the **CONSTRUCTION OF ADDITIONAL**

**BREASTING STRUCTURES FOR POWER BARGE 120 AT MOGPOG,  
MARINDUQUE (LuzP21Z1352Sc) of the National Power Corporation.**

- (k) We acknowledge that failure to sign each and every page of this Bid Letter, including the Bill of Quantities, shall be a ground for the rejection of our bid.

Name: \_\_\_\_\_

In the capacity of: \_\_\_\_\_

Signed: \_\_\_\_\_

Duly authorized to sign the Bid for and on behalf of: \_\_\_\_\_

Date: \_\_\_\_\_



Standard Form No. : NPCSF-INFR-15

**SUMMARY SHEETS OF MATERIALS PRICES, LABOR RATES  
AND EQUIPMENT RENTAL RATES**

Name of Bidder : \_\_\_\_\_

---

**I. Unit Prices of Materials**

Materials Description	Unit	Unit Price
1.		
2.		
3.		
4.		
5.		
6.		
7.		

**II. Manpower Hourly Rates**

Designation	Rate/Hr.
1.	
2.	
3.	
4.	
5.	
6.	
7.	

**III. Equipment Hourly Rental Rates**

Equipment Description	Rental Rate/Hr.
1.	
2.	
3.	
4.	
5.	
6.	
7.	

---

Name, Signature of Authorized Representative

---

Designation

SECTION VI

**BID DRAWINGS**

**SECTION VI – BID/REFERENCE DRAWINGS****CW – CIVIL WORKS**

<b><u>DRAWING NO.</u></b>	<b><u>TITLE</u></b>
ABSM-BDC-14.001	GENERAL LAYOUT
ABSM-BDC-14.002	SITE DEVELOPMENT PLAN
ABSM-BDC-14.003	SECTION VIEW OF PB & STRUCTURES
ABSM-BDC-14.004	BREASTING DOLPHINS (Plan, Elevation and Sections)
ABSM-BDC-14.005	PRESTRESSED CONCRETE PILES
ABSM-BDC-14.006	USED RUBBER TIRE FENDER



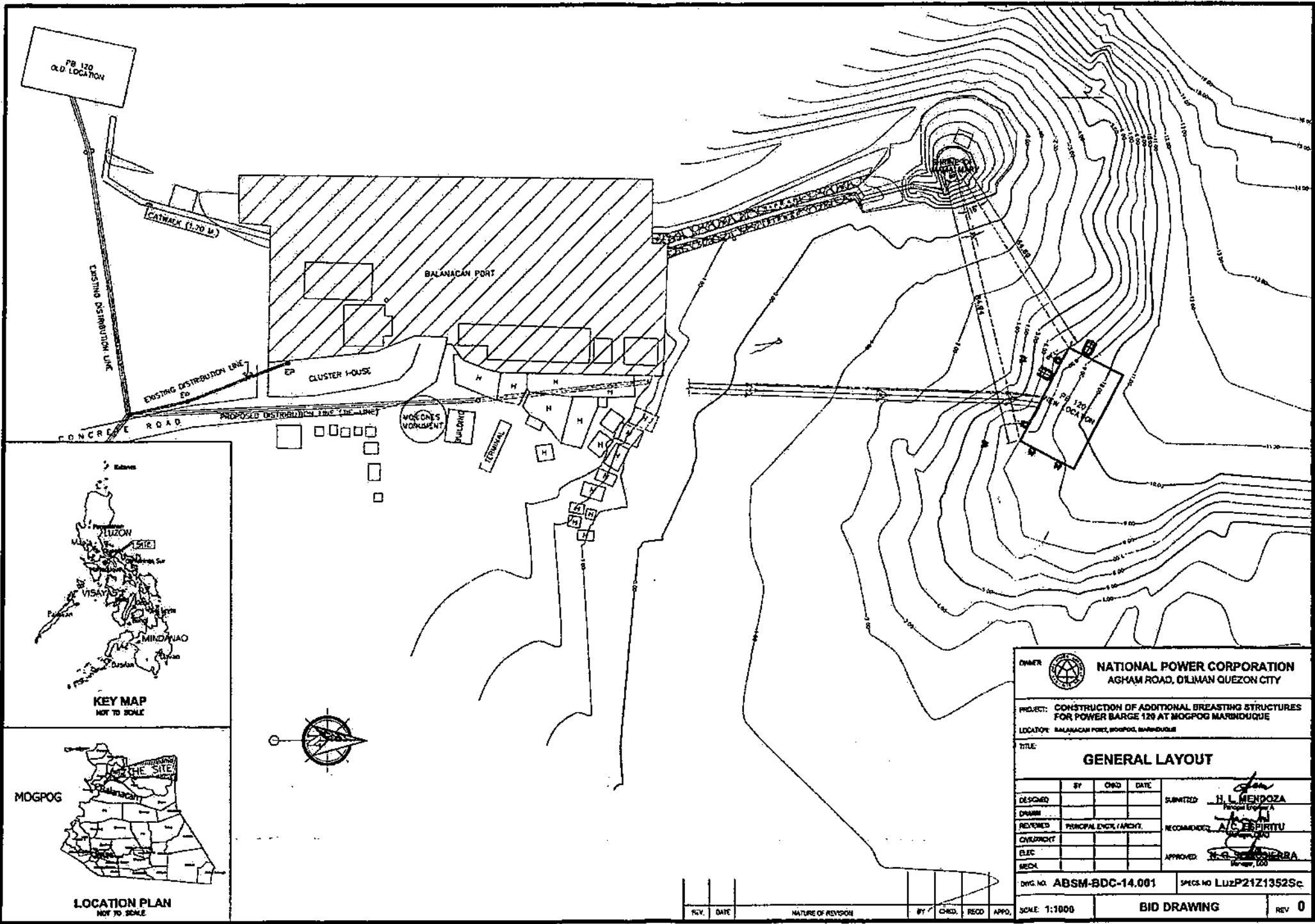

PB 120  
OLD LOCATION

PATWAK (1.70 M.)

BALANACAN PORT

CLUSTER HOUSE

VOLCANO'S  
WORKMENT  
BUILDING



PB 120  
NEW LOCATION

EXISTING DISTRIBUTION LINE  
CONCRETE ROAD  
EXISTING DISTRIBUTION LINE

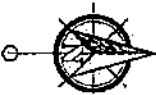
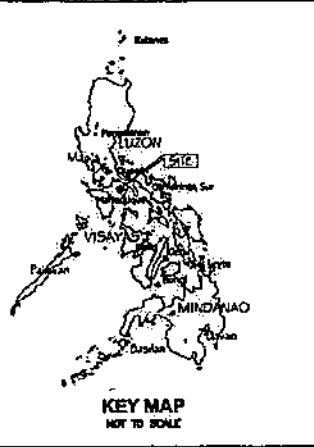
EXISTING DISTRIBUTION LINE  
PROPOSED DISTRIBUTION LINE (12C LINE)



OWNER		 <b>NATIONAL POWER CORPORATION</b> AGHAM ROAD, OILMAN QUEZON CITY	
PROJECT: CONSTRUCTION OF ADDITIONAL BREASTING STRUCTURES FOR POWER BARGE 120 AT MOGPOG MARINAQUE			
LOCATION: BALANACAN PORT, MOGPOG, MARINAQUE			
TITLE: <b>GENERAL LAYOUT</b>			
DESIGNED	BY	CHKD	DATE
DRAWN			
REVIEWED	PRINCIPAL ENGR. / ARCHT.		RECOMMENDED
CHECKED			
ELEC			APPROVED
MECH			
DWG. NO. <b>ABSM-BDC-14.001</b>		SPCS. NO. <b>LUP21Z1352Sc</b>	
SCALE: 1:1000		BID DRAWING	
REV.	DATE	NATURE OF REVISION	BY / CHKD. / RECD. / APPD.



  
 H. L. MENDOZA  
 Principal Engineer A  
  
 A. C. ESPERITU  
 Principal Engineer B  
  
 N. G. SERRERA  
 Manager, E&C

REV 0

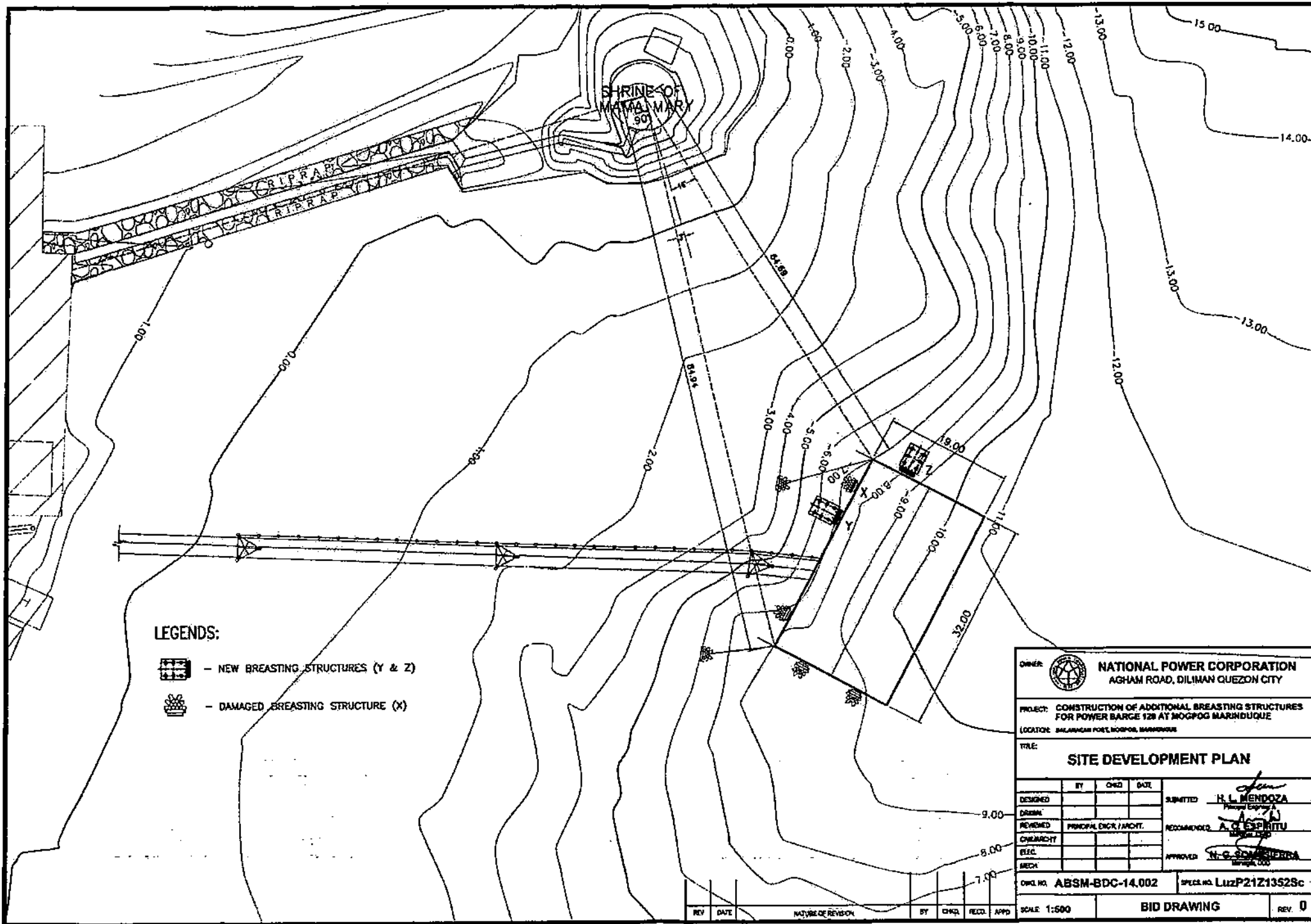



**LEGENDS:**

-  - NEW BREASTING STRUCTURES (Y & Z)
-  - DAMAGED BREASTING STRUCTURE (X)

		<b>NATIONAL POWER CORPORATION</b> AGHAM ROAD, DILIMAN QUEZON CITY										
<b>PROJECT:</b> CONSTRUCTION OF ADDITIONAL BREASTING STRUCTURES FOR POWER BARGE 128 AT MOGPOG MARINDUQUE												
<b>LOCATION:</b> BALARANAN POST, MOGPOG, MARINDUQUE												
<b>TITLE:</b> <b>SITE DEVELOPMENT PLAN</b>												
DESIGNED	BY	CHKD	DATE	SUBMITTED <i>H. L. MENDOZA</i> <small>Principal Engineer</small> RECOMMENDED <i>A. O. ESPRITU</i> <small>Senior Engineer</small> APPROVED <i>H. C. SOMAQUIERRA</i> <small>Manager, E&amp;C</small>								
DRAWN												
REVIEWED	PRINCIPAL ENGR. / ARCHT.											
CHEMIST												
ELEC.												
MECH.												
DWG. NO. <b>ABSM-BDC-14.002</b>		SPEC. NO. <b>L12ZP21Z1352Sc</b>										
REV		DATE		NATURE OF REVISION		BY	CHKD	REC'D	APP'D	SCALE: 1:500	<b>BID DRAWING</b>	REV. <b>0</b>

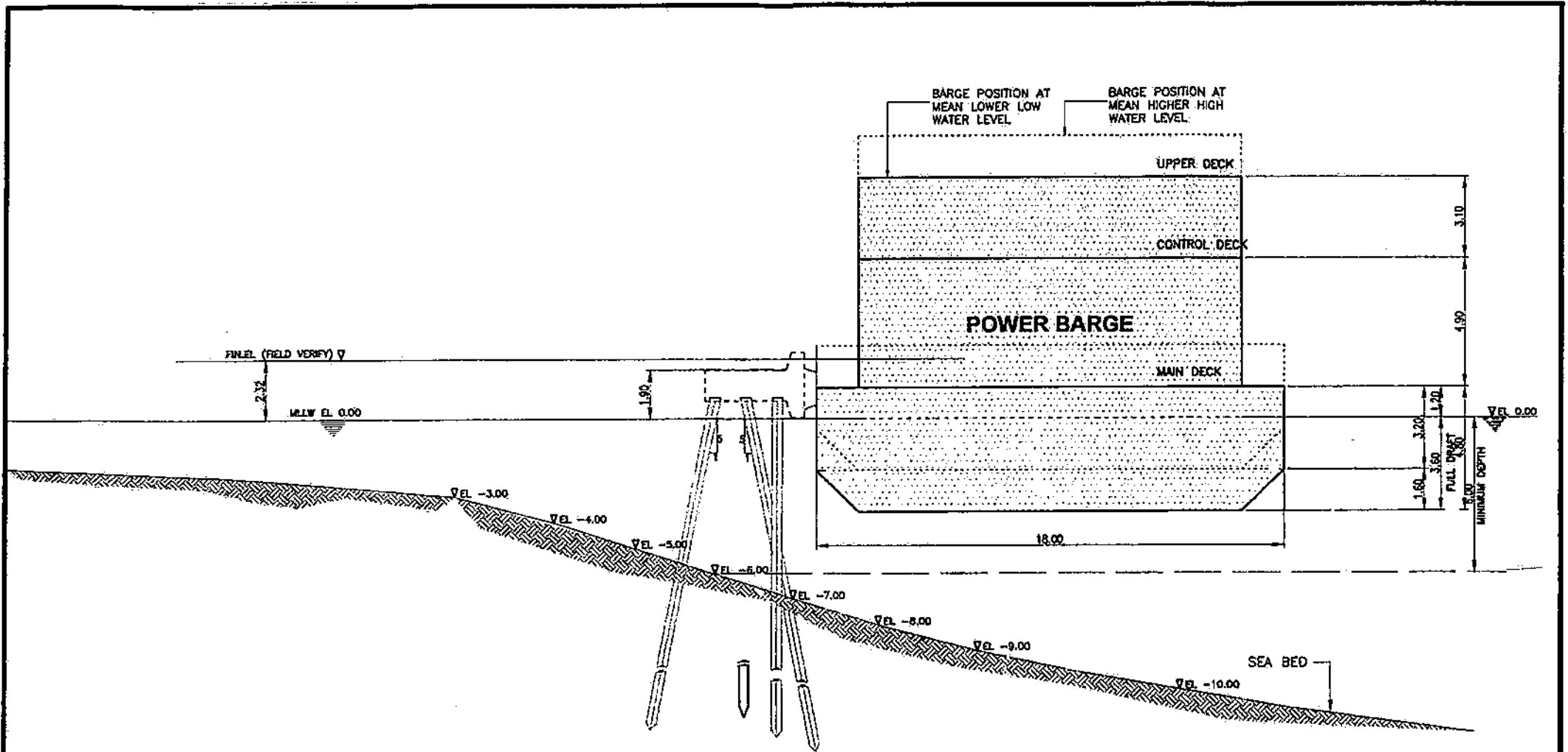

FIN. EL. (FIELD VERIFY) ▽

MLLW EL. 0.00

▽ EL. -3.00

▽ EL. -4.00

▽ EL. -5.00

▽ EL. -6.00

▽ EL. -7.00

▽ EL. -8.00

▽ EL. -9.00

▽ EL. -10.00

SEA BED

**ELEVATION**  
SCALE 1:150

**NOTES:**

1. ALL DIMENSIONS AND ELEVATIONS ARE IN METERS UNLESS OTHERWISE INDICATED.
2. VERTICAL DATUM SHALL BE REFERRED TO MEAN LOWER LOW WATER (MLLW) WHICH IS EL 0.00
3. FIELD VERIFY THE PROPOSED EXACT LOCATION OF POWER BARGE TO CHECK THE MINIMUM REQUIRED WATER DEPTH PRIOR TO STAKING.

OWNER:		 <b>NATIONAL POWER CORPORATION</b> AGHAM ROAD, DILIMAN, QUEZON CITY	
PROJECT:		CONSTRUCTION OF ADDITIONAL BREASTING STRUCTURES FOR POWER BARGE 126 AT MOGPOG MARINDUQUE	
LOCATION:		BALANCIAN PORT, MOGPOG, MARINDUQUE	
TITLE:		<b>SECTION VIEW OF PB AND STRUCTURES</b>	
DESIGNED	BY	CHECK	DATE
DRAWN			
REVIEWED	PRINCIP. ENGR./ARCHT.	RECOMMENDED	
CHECKED		APPROVED:	
MECH.			
DWG. NO.	ABSM-CNC-14.003	SPEC. NO.	LuzP21Z1352Sc
SCALE:	1:150	BID DRAWING	
REV. NO.	0		

REV.	DATE	NATURE OF REVISION	BY	CHECK	RECD.	APPR.

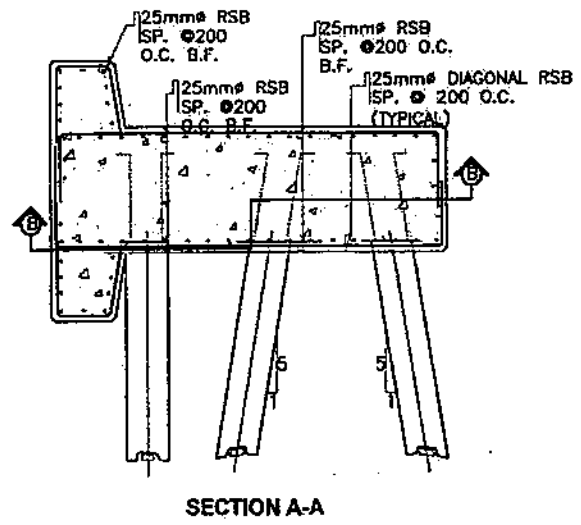
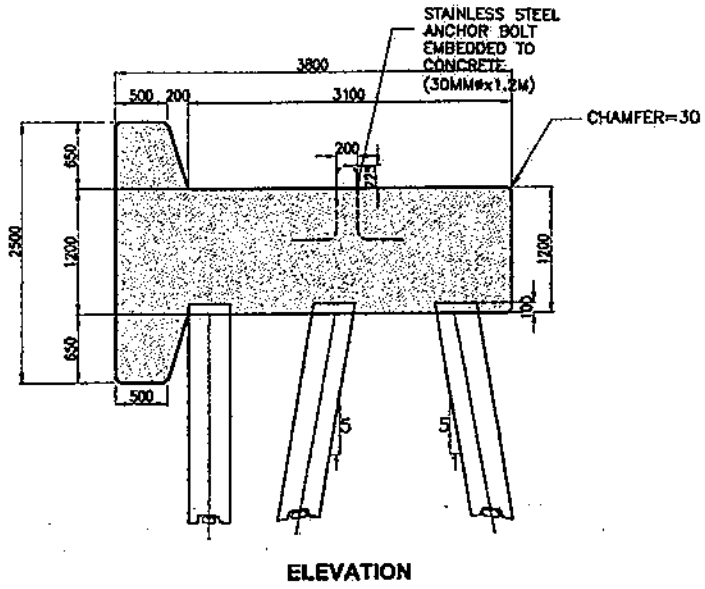
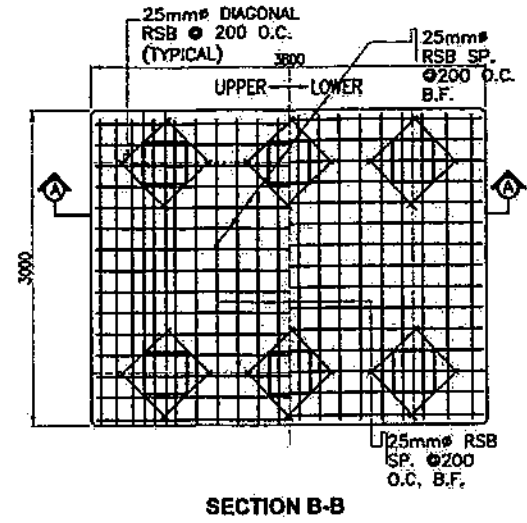
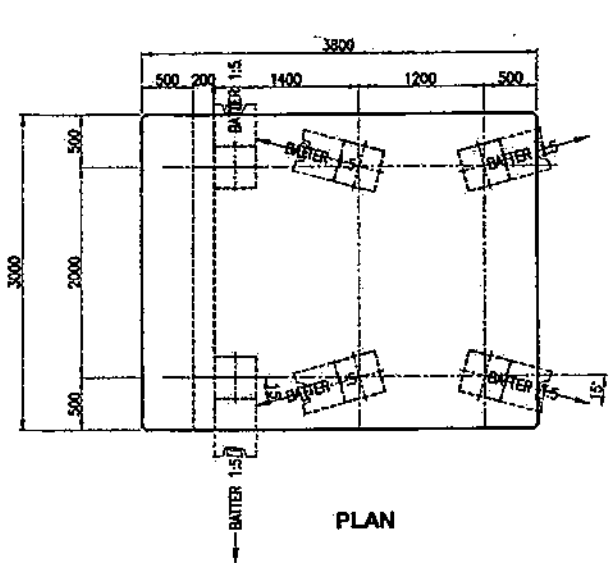

TYPICAL BREASTING DOLPHIN  
SCALE 1:50

OWNER		 <b>NATIONAL POWER CORPORATION</b> AGHAM ROAD, DILIMAN, QUEZON CITY	
PROJECT		CONSTRUCTION OF ADDITIONAL BREASTING STRUCTURES FOR POWER BARGE 120 AT MOGPOG MARINAQUE	
LOCATION		MOGPOG MARINAQUE, MOGPOG MARINAQUE	
TITLE		<b>BREASTING DOLPHINS</b> (PLAN, ELEVATION AND SECTIONS)	
DESIGNED	BY	CHKD	DATE
DRWING			
REVIEWED	PRINCIPAL ENGR / ARCHT.		QUANTITY
CALCULATED			H. L. MENDOZA Principal Engineer
ELEC			RECOMMENDED
MECH			A. C. ESTERITA MECH ENGR
APPROVED		R. G. SORIANO MECH ENGR	
DWG. NO.		ABS-M-BDC-14.004	
SPEC. NO.		LuzP21Z13525c	
SCALE: 1:150		BID DRAWING	
REV.	DATE	NATURE OF REVISION	BY
			CHKD.
			RECD.
			APPD.
			REV. NO. 0

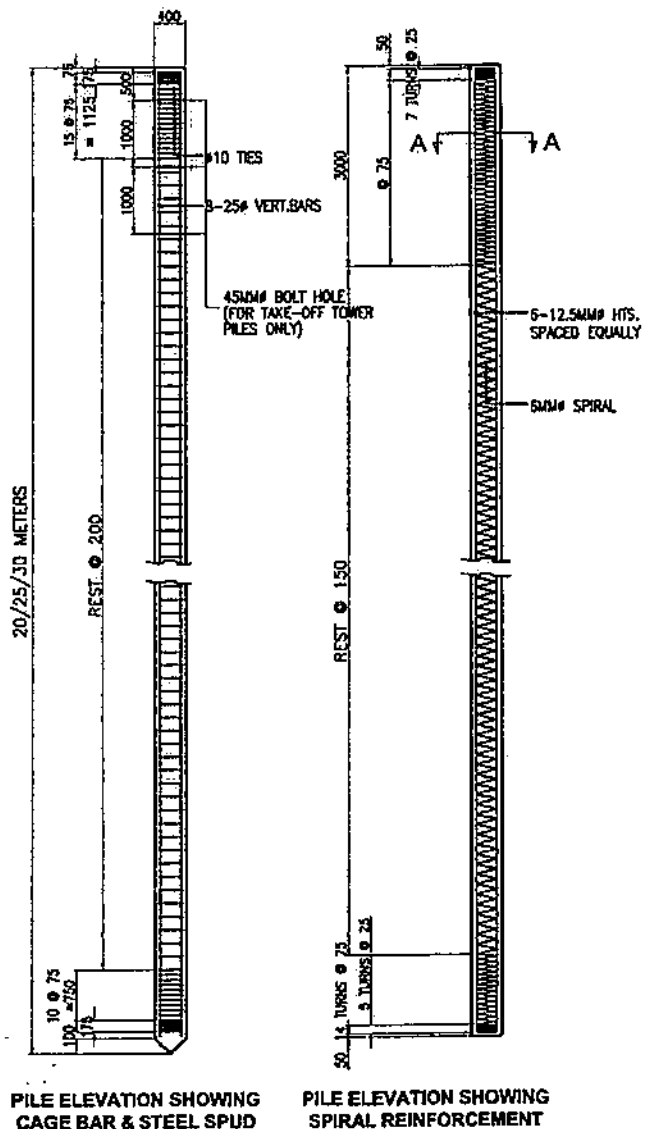

PILE ELEVATION SHOWING CAGE BAR & STEEL SPUD

PILE ELEVATION SHOWING SPIRAL REINFORCEMENT

**PRE-STRESSED CONCRETE PILES**

SCALE 1:80

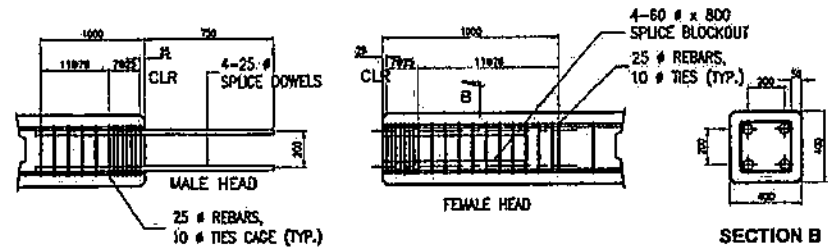

**PILE SPLICING DETAIL**

SCALE 1:30

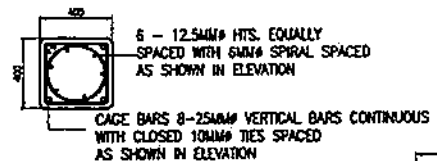

**SECTION A-A**

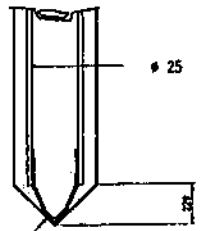

**PILE AND SPUD SECTION**

SCALE 1:30

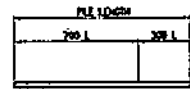

1 POINT PICK-UP

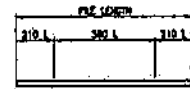

2 POINT PICK-UP

**LIFTING HOOK DETAIL**

SCALE 1:30

OWNER:  NATIONAL POWER CORPORATION AGHAM ROAD, DILMAN, QUEZON CITY	
PROJECT: CONSTRUCTION OF ADDITIONAL BREASTING STRUCTURES FOR POWER BARGE 120 AT MOCPOG MARBIDUQUE	
LOCATION: BALANACAN PORT, MOCPOG, MARBIDUQUE	
TITLE: <b>PRESTRESSED CONCRETE PILES</b>	
DESIGNED	BY: CHD DATE:
DRAWN	BY: CHD DATE:
REVIEWED	PRINCIPAL ENGR. / ARCHT.
CYCLING/CHT	
ELEC	
MECH	
SUBMITTED: <i>H. L. MENDOZA</i> RECOMMENDED: <i>A. E. ESPRITU</i> APPROVED: <i>N. G. ...</i>	
DWG NO: <b>ABSM-BDC-14.005</b>	SPECS NO: <b>LuzP21Z135ZSc</b>
SCALE: 1:160	<b>BID DRAWING</b>
REV. NO. 0	

REV.	DATE	NATURE OF REVISION	BY	CHKD	RECD	APPD

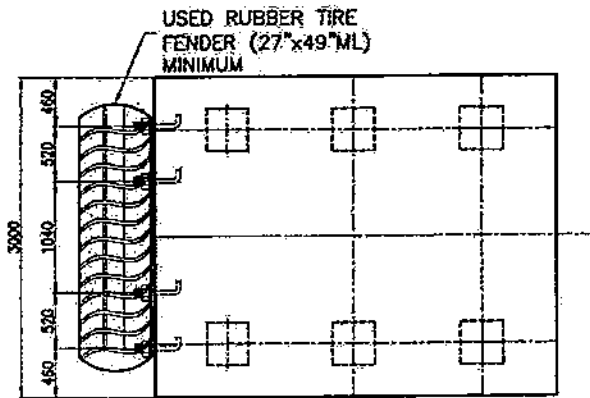

PLAN

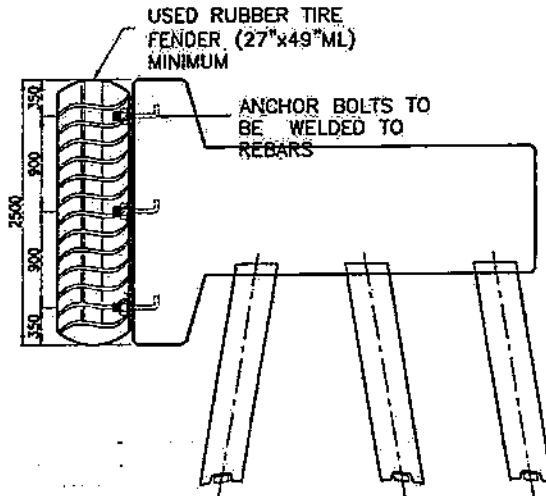

SIDE ELEVATION

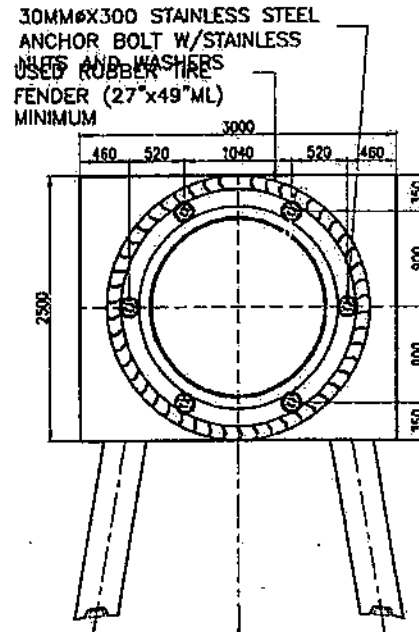

FRONT ELEVATION

**USED RUBBER TIRE FENDER**  
SCALE 1:50

OWNER:  NATIONAL POWER CORPORATION AGHAM ROAD, DILIMAN, QUEZON CITY	
PROJECT: CONSTRUCTION OF ADDITIONAL BREASTING STRUCTURES FOR POWER BARGE 120 AT MOGPOG MARRIQUOUE LOCATION: BALANACAN POINT, MOGPOG, BARRIQUOUE	
TITLE: <b>USED RUBBER TIRE FENDER</b> (PLAN AND ELEVATION)	
DESIGNED: _____	SUBMITTED: <i>H. L. MENDOZA</i>
DRAWN: _____	RECOMMENDED: <i>A. C. ESPERITU</i>
REVIEWED: PRINCIPAL ENGR./ARCHT.	APPROVED: <i>H. O. DOMESTICERRA</i>
CIVIL/ARCHT: _____	MECH: _____
ELEC: _____	
MECH: _____	
DWG. NO. <b>ABSM-BDC-14.006</b>	SPEC. NO. <b>LuzP21Z1352Sc</b>
SCALE: <b>1:150</b>	<b>BID DRAWING</b>
REV. NO. <b>0</b>	

REV.	DATE	NATURE OF REVISION	BY	CHKD.	RECD.	APPD.